



Recent results and plans of the NA64 experiment

Mikhail Kirsanov

JINR



Outline

- Motivation
- The NA64 experiment (initial motivation, development)
- Simulation of the Dark Matter production: DMG4 package
- Method, its development, Thermal DM
- Plans for the invisible mode
- Other types of DM, B-L model
- ALP search in invisible mode configuration
- Visible mode: X-boson, results, new project, new ideas
- $(g-2)_\mu$ and NA64 μ results and plans
- NA64h: searches in hadron beams

Vector portal to Dark Sector (initial motivation)



Okun, Holdom'86 .. $\alpha_D = e_D^2/4\pi$

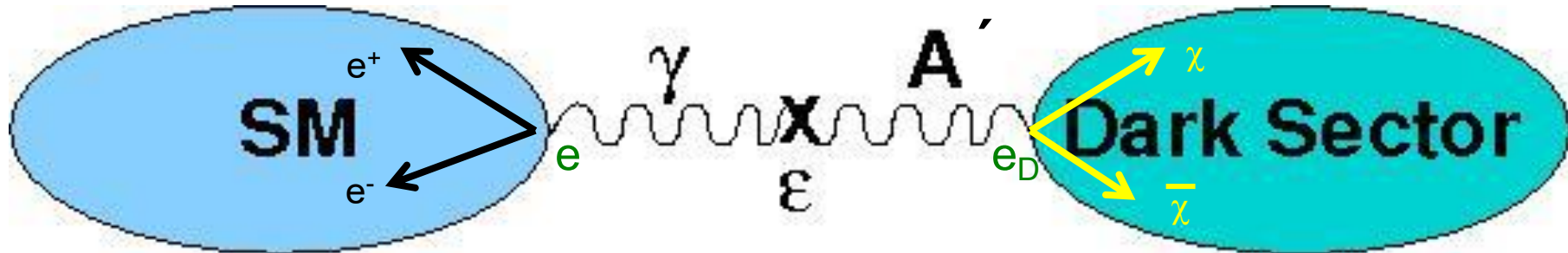

- new massive boson A' (dark photon) which has kinetic mixing with ordinary photon: $\Delta L = \epsilon/2 F^{\mu\nu} A'_{\mu\nu}$
- Production: A' - bremsstrahlung $e^- Z \rightarrow e^- Z A'$, $\sigma \sim Z^2 \epsilon^2 / m_{A'}^2$
- Decays:
 - Visible: $A' \rightarrow e^+e^-, \mu^+\mu^-, \text{hadrons}, \dots$
 - Invisible: $A' \rightarrow \chi\bar{\chi}$ if $m_{A'} > 2m_\chi$ assuming $\alpha_{DM} \sim \alpha \gg \epsilon$.
 Can explain $(g-2)_\mu$, astrophys. observations
 - Cross section for χ -DM annihilation: $\sigma v \sim [\alpha_{DM} \epsilon^2 (m_\chi/m_{A'})^4] \alpha / m_\chi^2$



Thermal dark matter

- Assume that in the early Universe dark matter is in equilibrium with the SM matter. At some temperature the dark matter decouples
- DM density today tells us about the annihilation cross-section. Correct DM density corresponds to $\langle \sigma_{\text{an}} v \rangle \sim O(1) \text{ pbn}$
- Most popular models of light (sub-GeV) dark matter χ :
 - Scalar dark matter
 - Majorana dark matter
 - Pseudo Dirac dark matter



Search for $A' \rightarrow$ invisible decays at CERN SPS

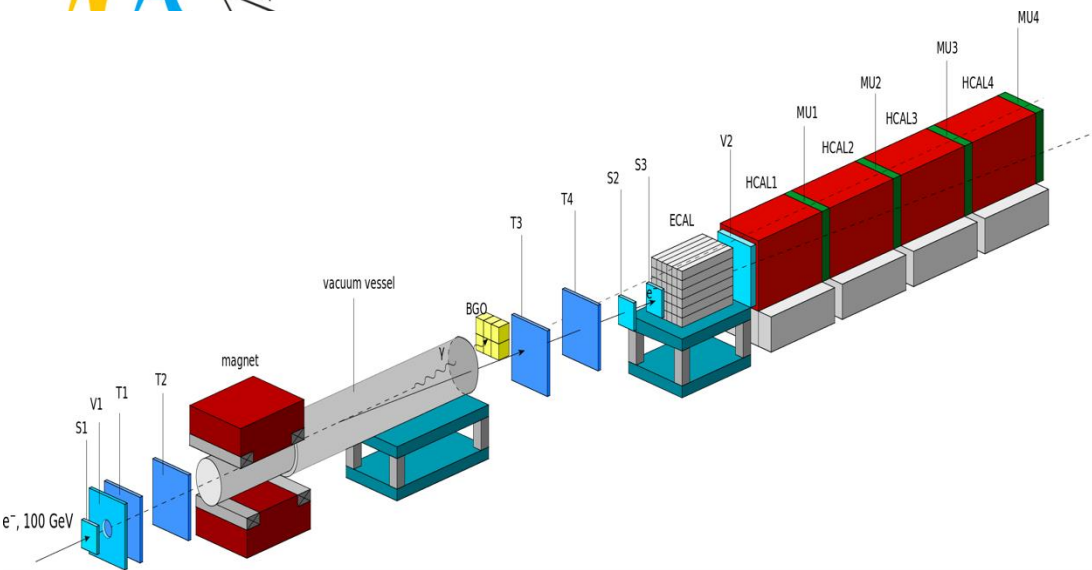

S.Andreas et al., arXiv: 1312.3309
S.G., PRD(2014)

Main components :

- clean 100 GeV e- beam
- e- tagging system: **MS+SRD**
- hermetic ECAL+HCAL

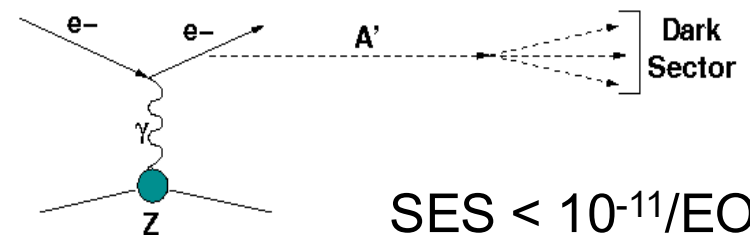

$$SES < 10^{-11}/EOT$$

Signature:

- in: 100 GeV e- track
- out: $E_{ECAL} < E_0$ shower in ECAL
- no energy in Veto and HCAL

Background:

- ◆ μ, π, K decays in flight
- ◆ upstream interactions
- ◆ Tail < 50 GeV in the e- beam
- ◆ Energy leak from ECAL+HCAL

NA64 in 2021-2022, permanent place at H4 prepared by the CERN Beam Division

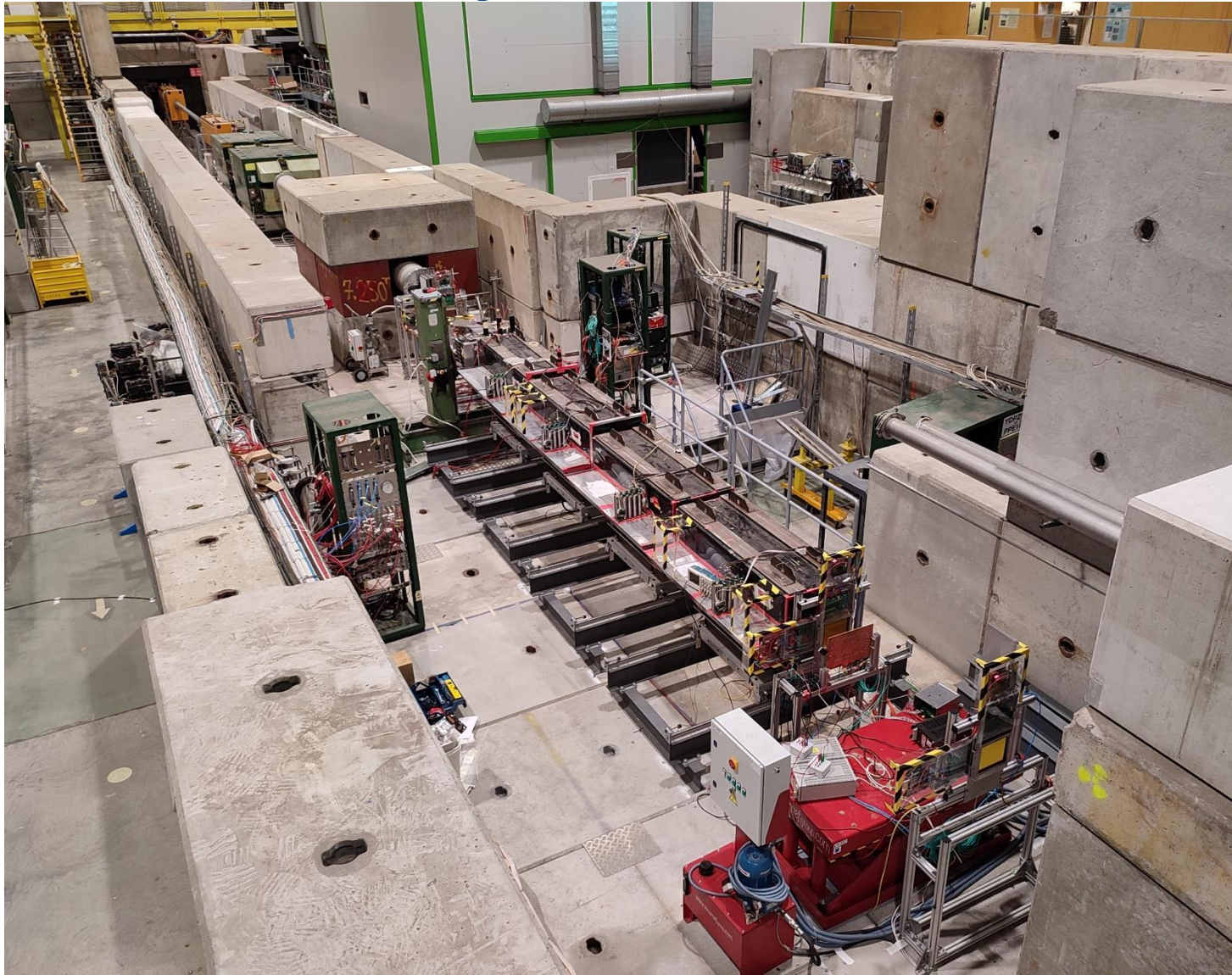
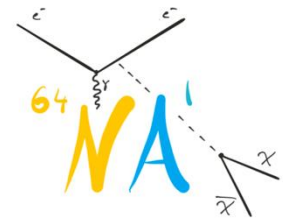



NA64 development

- 2016 – 2018 – initial runs
- 2021 – Permanent place in NA
- 2021, 2022 – new ECAL 5x6 (same design)
- 2022 – More compact geometry, new low material budget MM
- 2022 – Start to upgrade electronics
- 2022 - Added end spectrometer to study dimuons and possibly new physics
- 2024 – Add VHCAL0
- 2025 – Add VHCAL1
- 2025 – Use new more sensitive SRD, LYSO crystals from Chile, important for low energy positron runs
- 2025 – Use PKRCAL from INFN Genova group (PWO crystal better segmented target – calorimeter, 9x9 segmentation) in positron runs
- 2025 – New 3 times faster waveboard is used for PMT based detectors
- 2021 --> **SW:** Work on the DMG4 package for the simulation of DM events, development, improvements, testing
- 2025 --> **SW:** Waveform reconstruction using fits, potentially better energy resolution in conditions of high pile-up

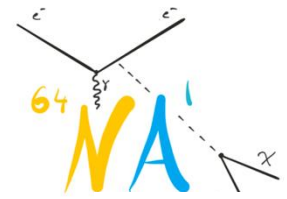

NA64 in 2022

* all dimensions in cm

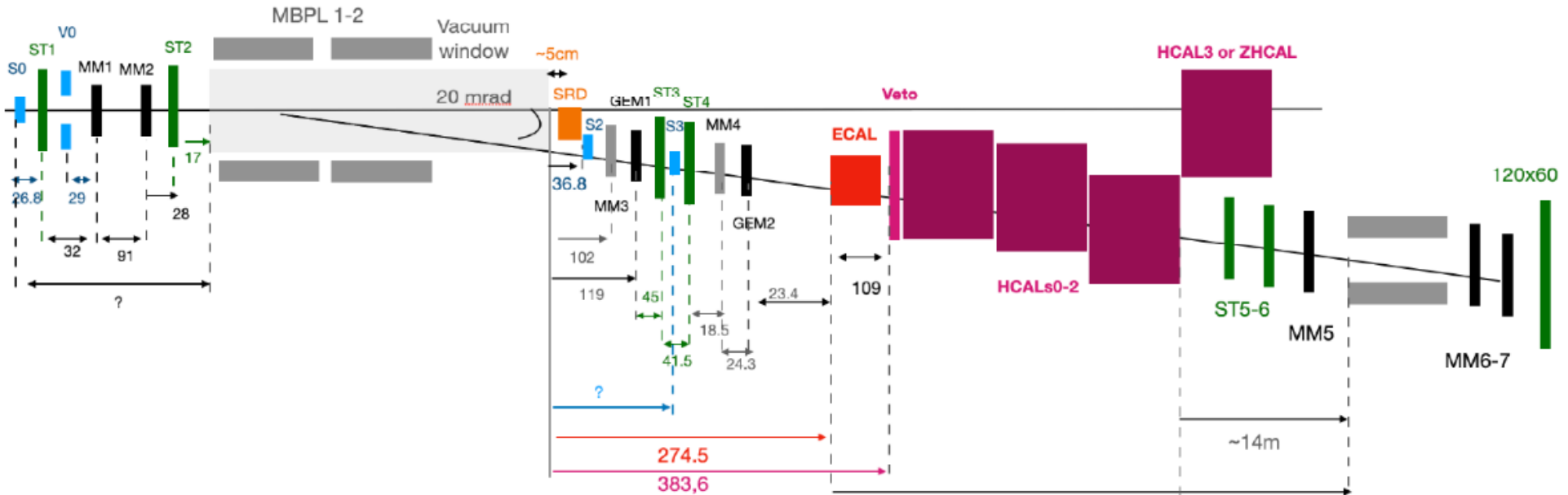



NA64 in 2025 - 2026

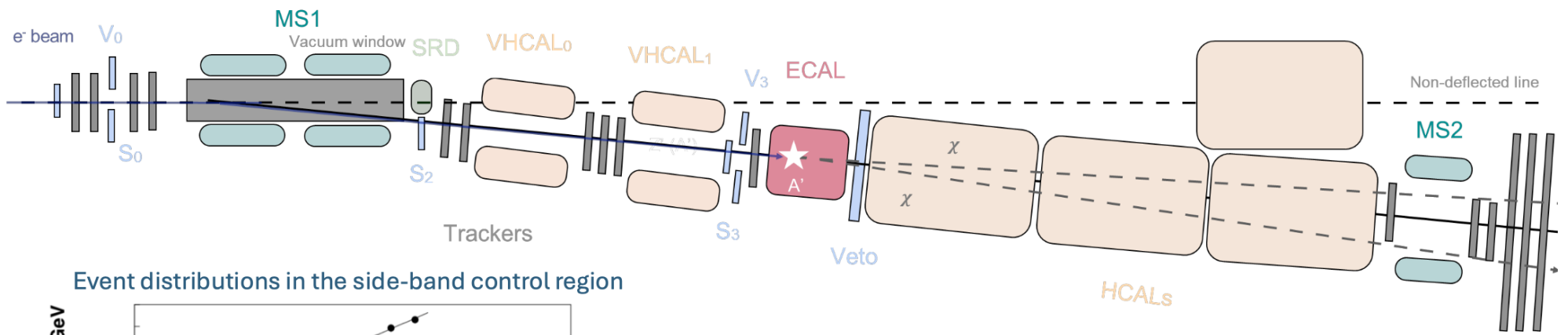

Event distributions in the side-band control region

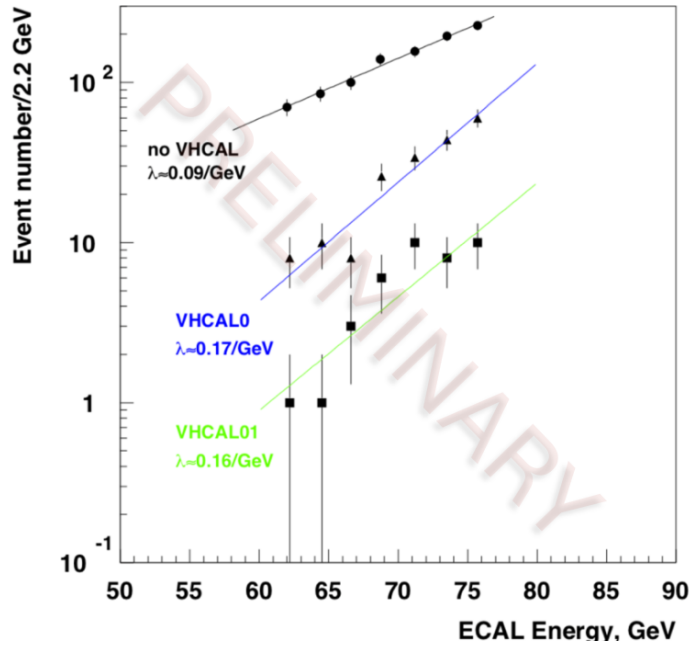

- Possible further steps to mitigate the background level after LS3:
 - Remove as much material as possible upstream of VHCAL0; optimize the positions of all detectors
 - Improve detection efficiency of VHCAL (new PMT readout)
 - Upgrade the setup with larger-acceptance HCAL modules from the M2 line (need of a new support structure)
- Preliminary plan: collect further statistic during 2026 run to finalize background studies before LS3 ($>10^{12}$ eOT combined with 2025)

L. Marsicano - 158th SPSC meeting 9/7/2025 9



Simulation of $eZ \rightarrow eZA'$; $A' \rightarrow$ invisible @ BG

A' emission in the process of e-m shower development.
 $\sigma(eZ \rightarrow eZA')$ (Bjorken et al. 2009)

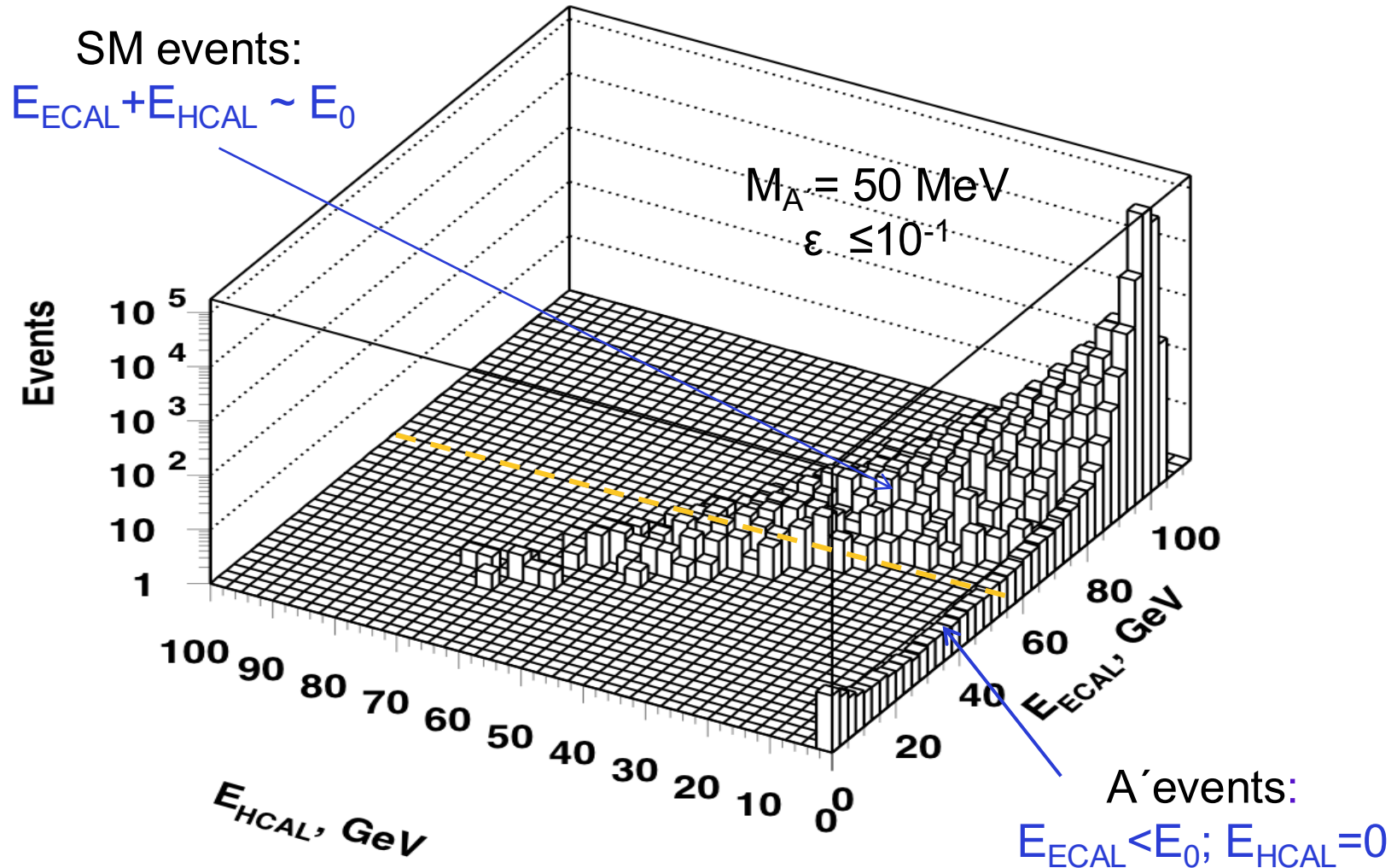



DM processes simulation: DMG4

- Fully Geant4 compatible package **DMG4** is developed [arXiv:2101.12192 \[hep-ph\]](https://arxiv.org/abs/2101.12192). Can be used in any full simulation program based on the Geant4 toolkit
- Bremsstrahlung processes off electrons and muons (like $eZ \rightarrow eZA'$), gamma conversion to ALP, annihilation processes (like $e^+e^- \rightarrow A' \rightarrow \chi\chi$) can be simulated
- DM messengers: vector (A'), axial vector, scalar, pseudoscalar, spin 2 (graviton), masses up to 3 GeV
- Invisible and visible (to SM particles) decays
- **For the total cross section we use the full matrix element calculations (ETL)** ([arXiv:1712.05706 \[hep-ph\]](https://arxiv.org/abs/1712.05706)) through the K-factors applied to the IWW cross sections. These K-factors can be as small as 1/15 for electrons at $M_A \sim 1$ GeV



DM processes simulation: DMG4(2)

- Simplified IWW approximation in e^+ beams for differential cross sections (messenger masses > 1 MeV), sufficient accuracy. Messenger energy and angle are sampled
- Tabulated e^+ beams differential cross section for masses < 1 MeV
- **Recently implemented WW approximation in muon beams**
Complicated analytical integration. Messenger energy and recoil muon angle are sampled by default (needed in analysis, see below)
- WW formulas are now extended to scalar mediators
- **Recently implemented: spin 2 messengers**
- **Recently implemented: semivisible decays of DM**
- Presented at ACAT-2021 and ACAT-2022
- **We continue to develop the package (convenience, new processes)**

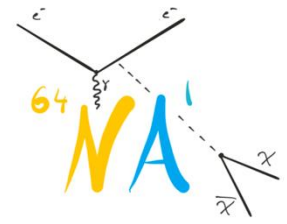

Analysis of data 2022

How is this shape formed?

- Electron – nuclear and gamma – nuclear interactions
- The main peak is cut off by trigger requirement $E_{\text{ECAL}} < 85\text{GeV}$

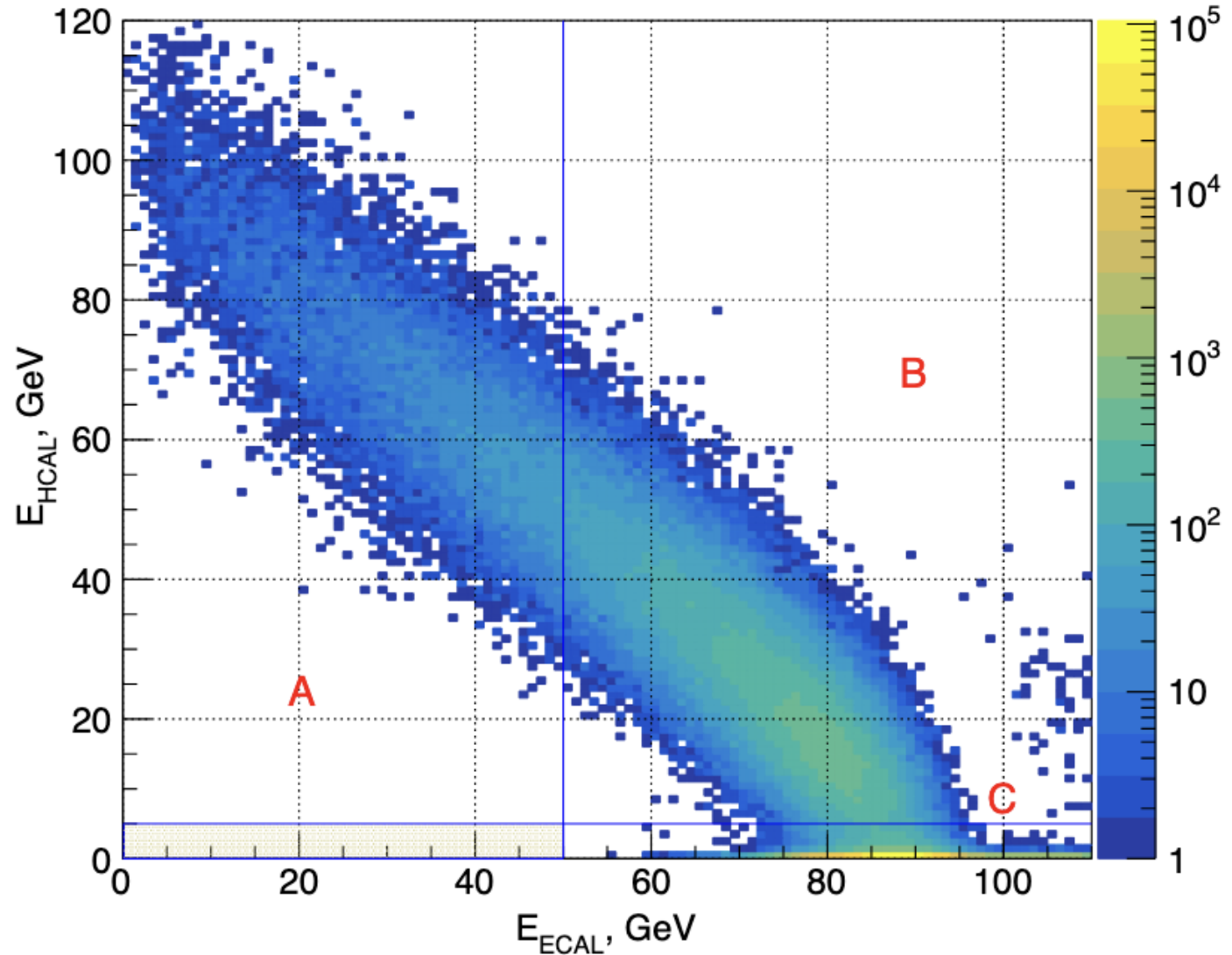

Background: example of extrapolation

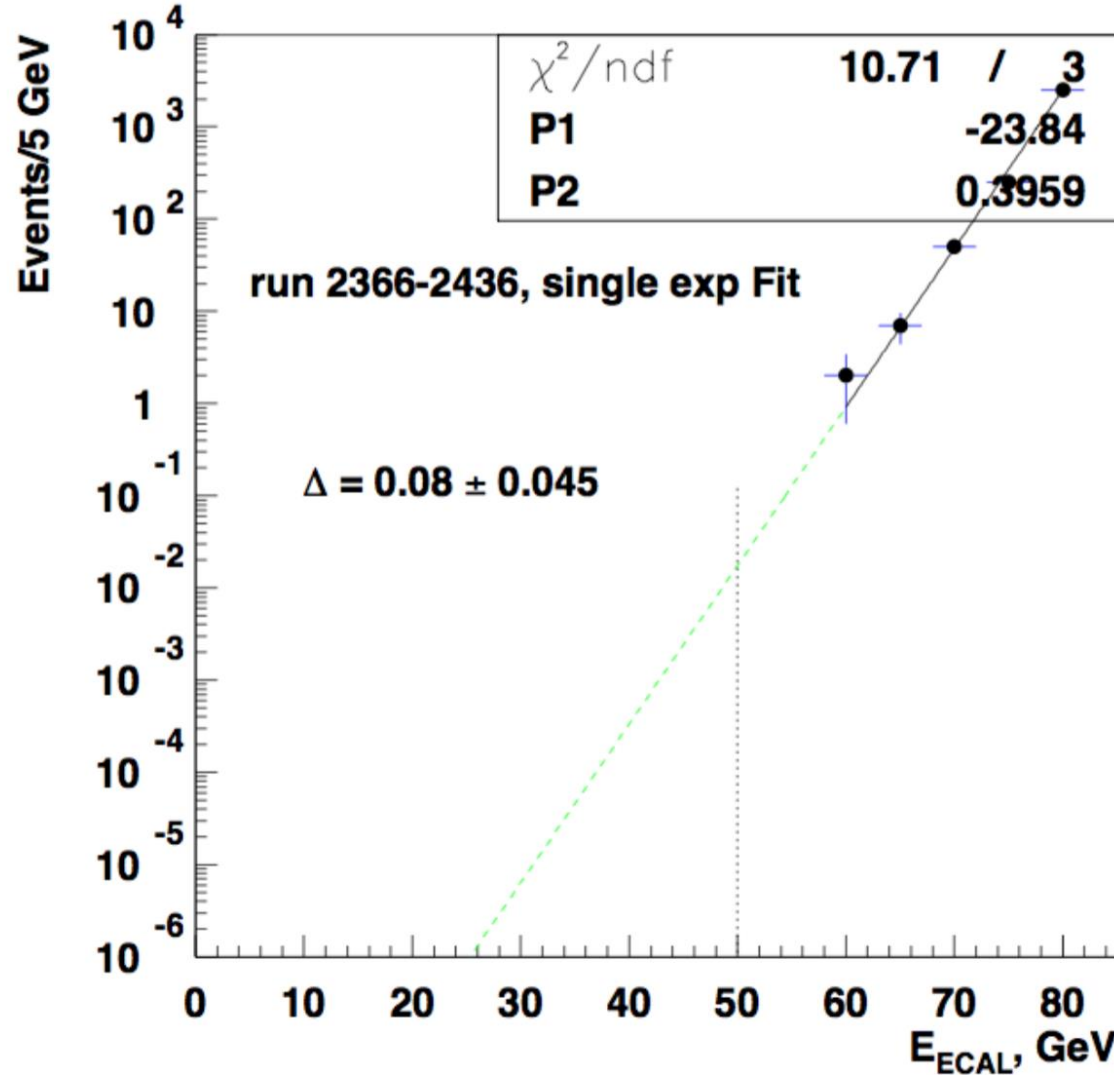

Background sources runs 2021 - 2022

Background source	Background, n_b
(i) dimuons losses or decays in the target	0.04 ± 0.01
(ii) $\mu, \pi, K \rightarrow e + \dots$ decays in the beam line	0.3 ± 0.05
(iii) lost γ, n, K^0 from upstream interactions	0.16 ± 0.12
(iv) Punch-through leading n, K_L^0	< 0.01
Total n_b (conservatively)	0.51 ± 0.13

BG from the beam elements (iii) is suppressed by multiplicity cuts in MM and Straw tubes and by HCAL Topo cuts. Estimated from extrapolation

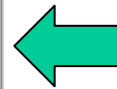



Results. Most recent on A' .

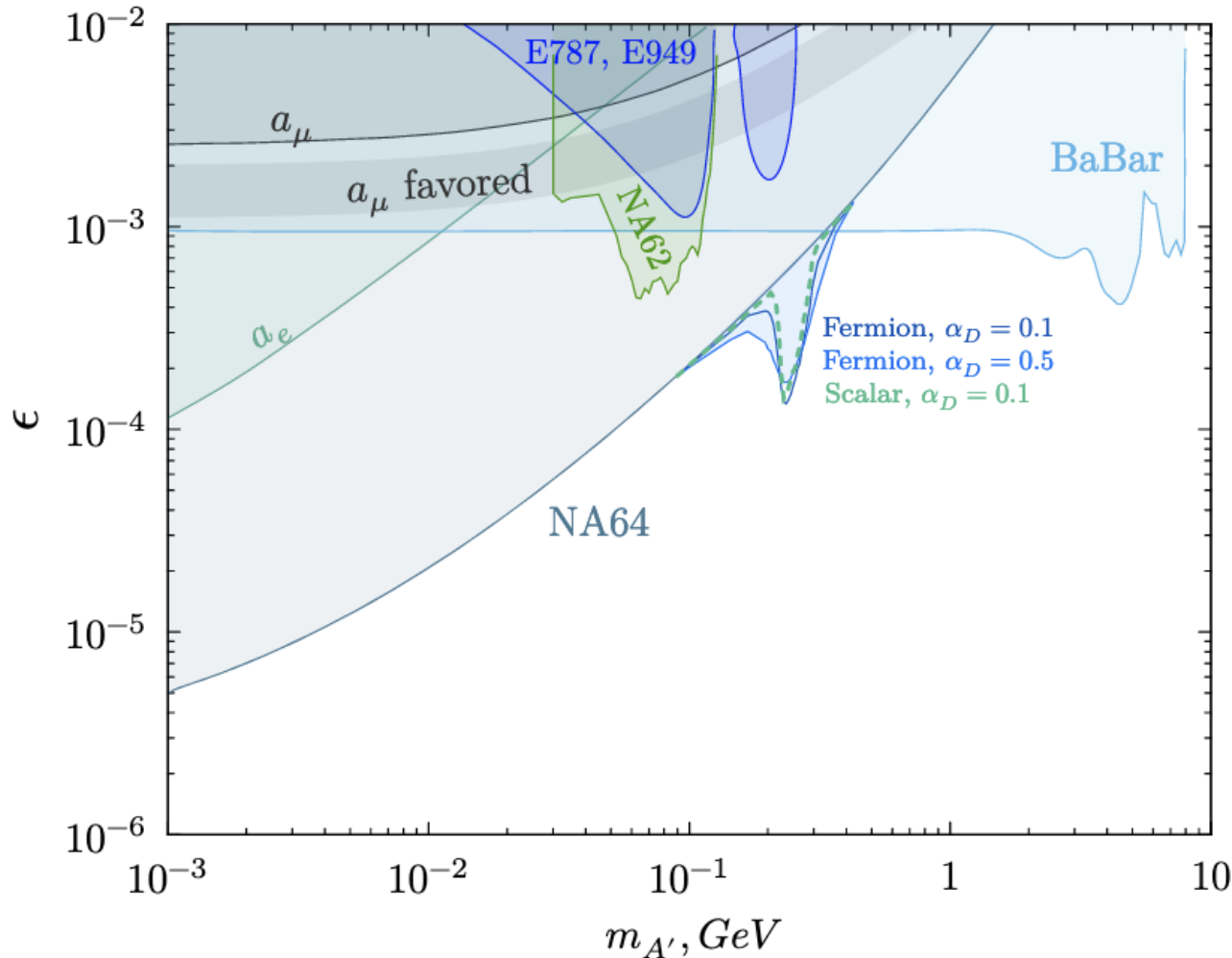

Phys. Rev. Lett. 131, 161801
(2023)

+ Resonant process:
shower positrons on
electrons of the target

$$e^+e^- \rightarrow A' \rightarrow \chi\chi$$

First addition
to the analysis:

Phys. Rev. D 104, L091701
(2021)

Goal: add statistics
accumulated in 2023 – 2026

$\sim 2 \cdot 10^{12}$ EOT

(2023 is completed)

Limits in “cosmological” variables with 2022 data and sub-GeV Thermal Dark Matter models

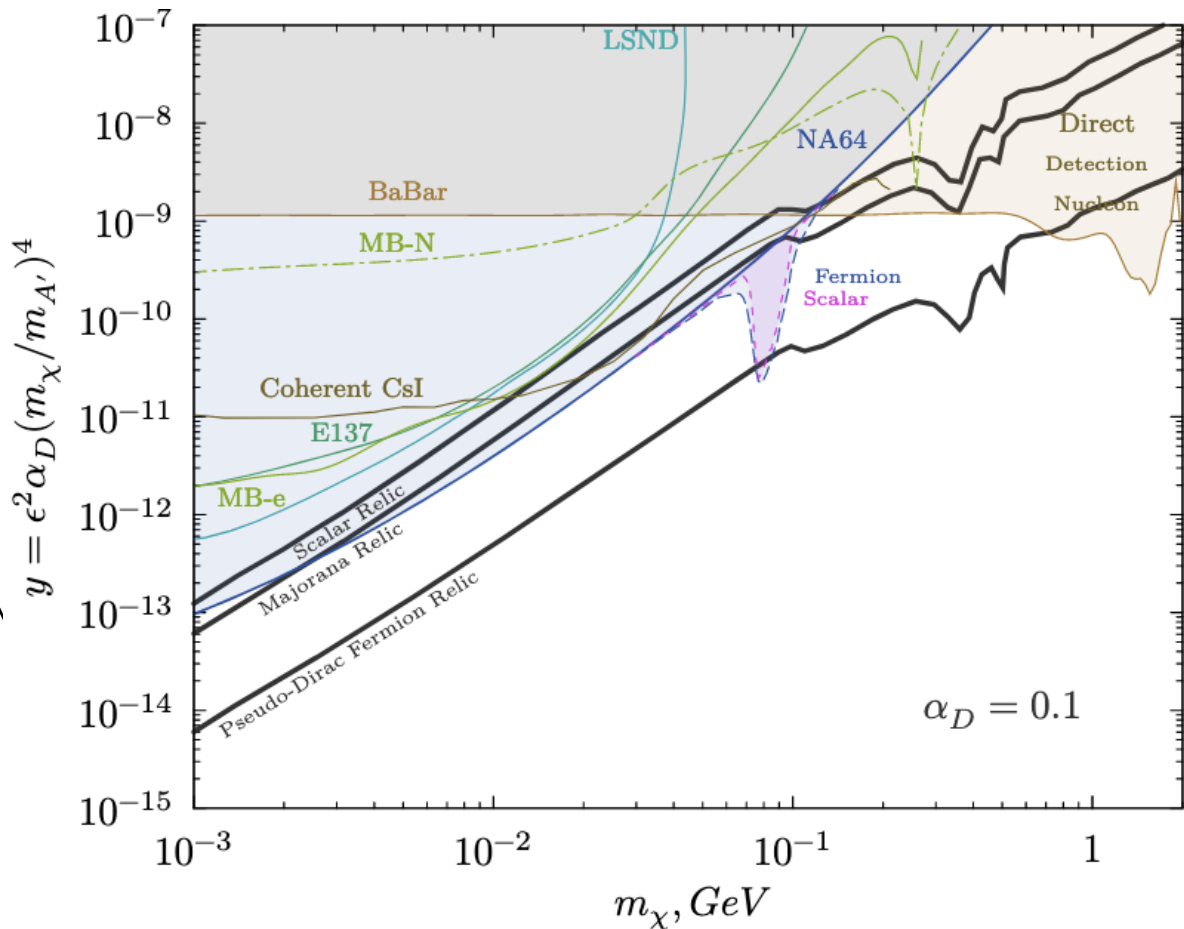

$$\alpha_D = 0.1, m_{A'} = 3m_\chi$$

For $\alpha_D = 0.1$ we cover two models and touch the third

Less strict limits for $\alpha_D > 0.1$

proportional to DM \leftrightarrow SM annihilation cross section



Limits on generic boson and $(g-2)_e$

$e^-Z \rightarrow e^-ZX; X \rightarrow \text{invisible}$

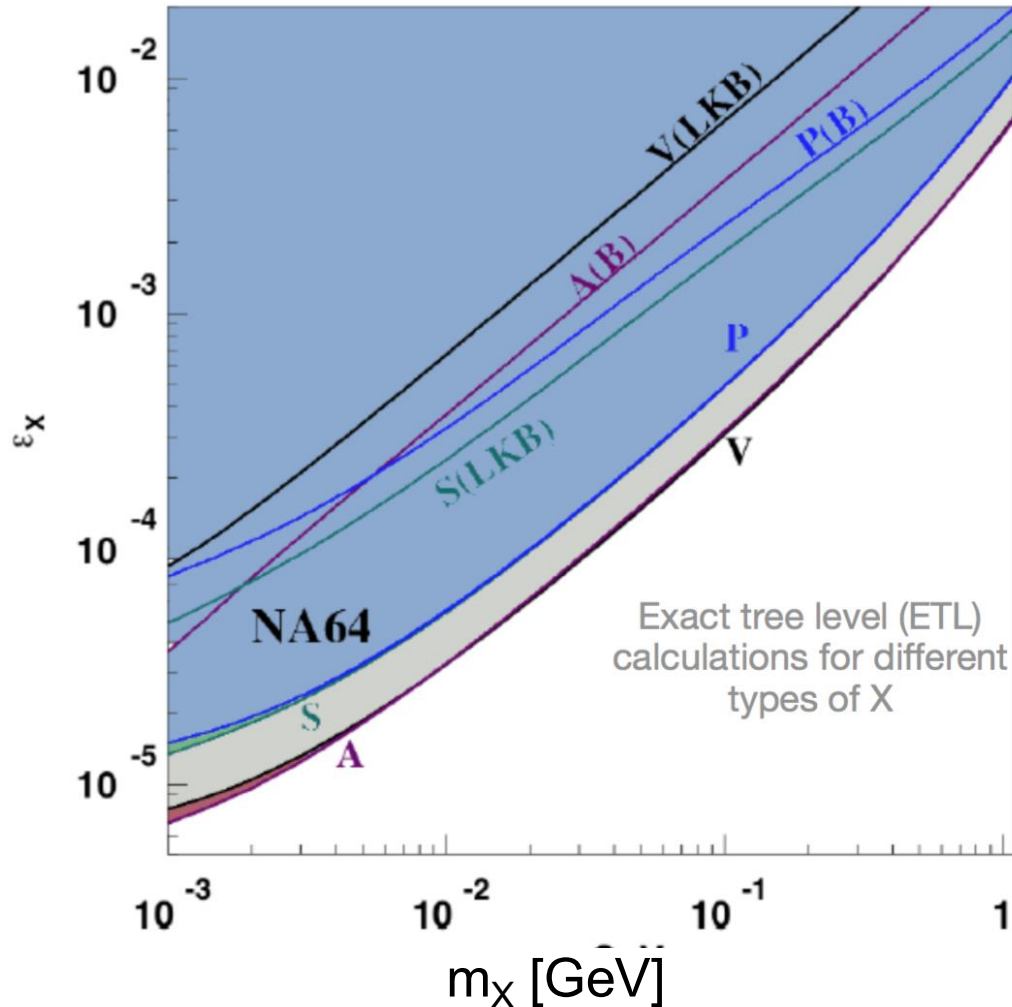

Consider also Scalar,
Pseudoscalar, Axial vector
Andreev et al.
PRL 126, 211802 (2021)

Results (tension) on Δa_e :
LKB $+1.6\sigma$,
Berkley -2.4σ



Limits on generic boson, new analysis

Preliminary, with 2022 data

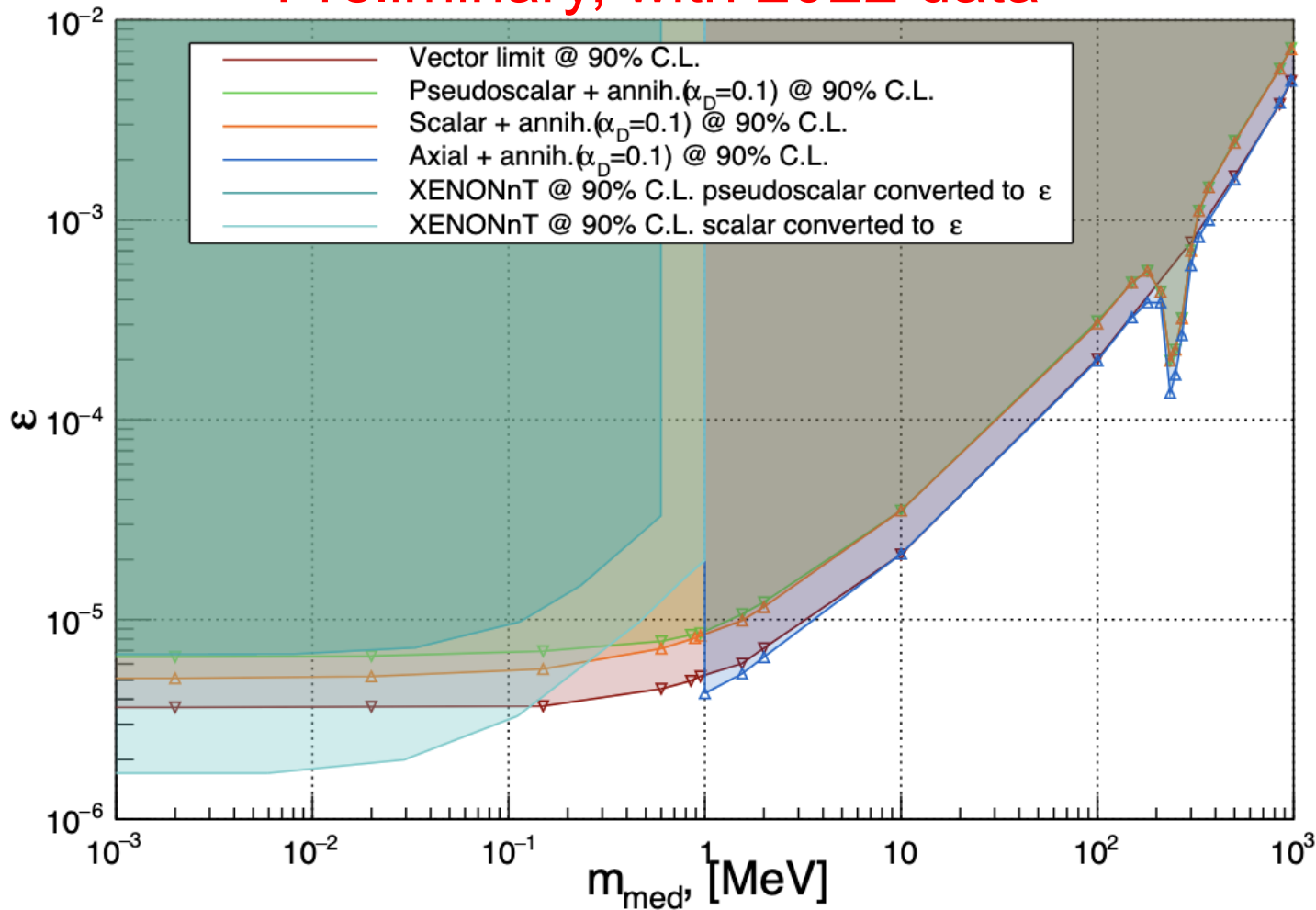

Consider also
Scalar,
Pseudoscalar,
Axial vector

+Annihilation

Extend to 1 KeV

Plan is to publish
together with 2023 -
2026



Constraints on B-L Z' (decaying to SM particles)

90% C.L. exclusion limits for U_{B-L} (scalar DM)

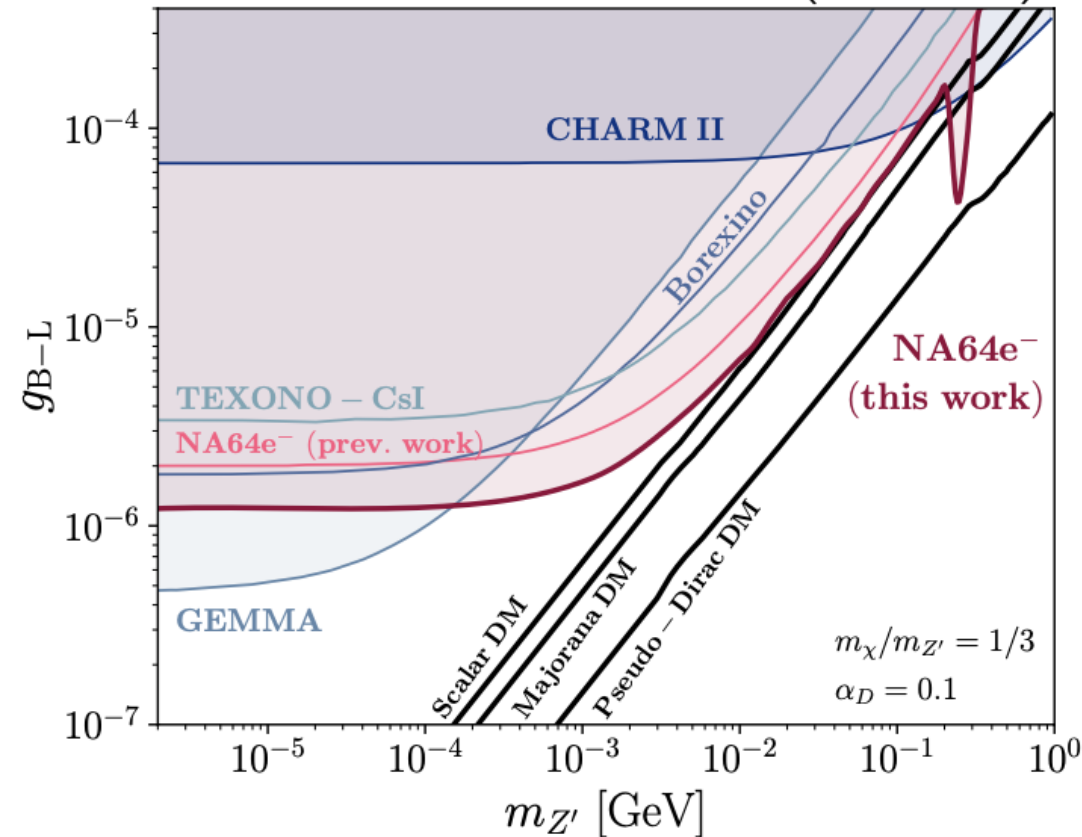

Better sensitivity than neutrino experiments!

Phys. Rev. Lett. (2022)

New result is being prepared for publication (datasets up to 2022, 3 times more statistics)

Sensitivity to y and some popular sub-GeV Thermal Dark Matter models

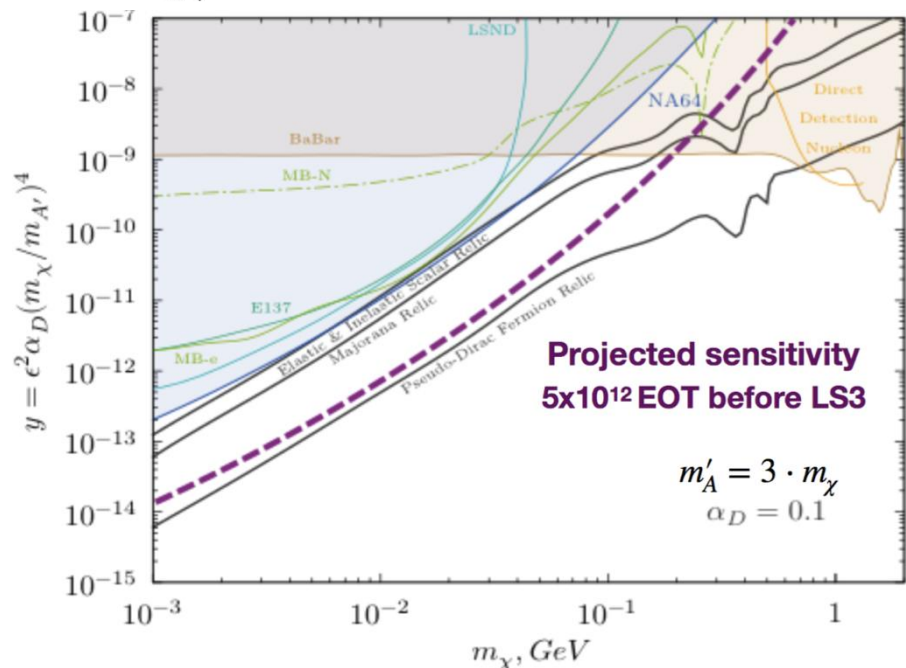
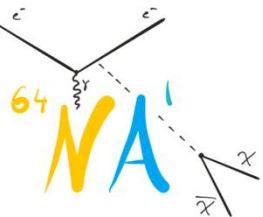

How to improve sensitivity above 100 MeV?

- **Annihilation.** Additional positron run in 2022 (already analysed), positron run at 70 GeV in 2023, 60, 40 GeV planned
- **NA64 μ** at the muon beam M2, later in this talk.

Analysed positron data 2022, green dashed – expected from 40 - 70 GeV positrons with $\sim 10^{11}$ POT

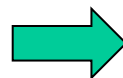

Additional region in positron beam is larger

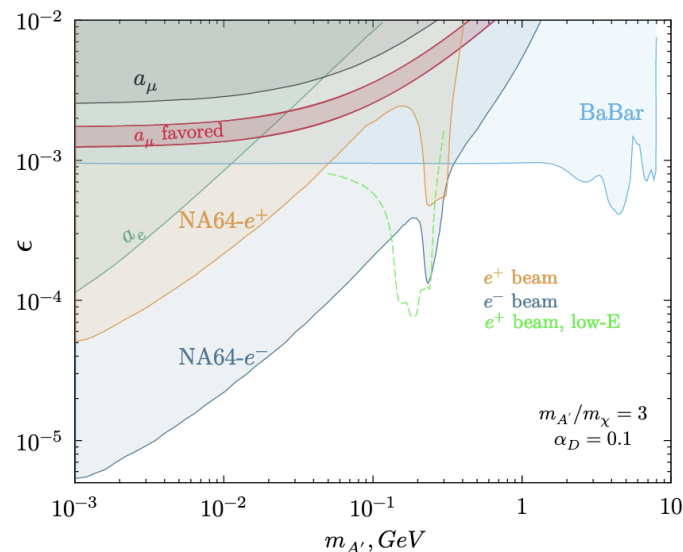
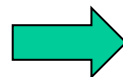

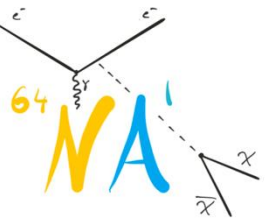

Axion-like particles (ALP) coupled to photons

New way of using the invisible mode geometry: visible decays!

Produced via Primakoff effect of gamma conversion on nuclei

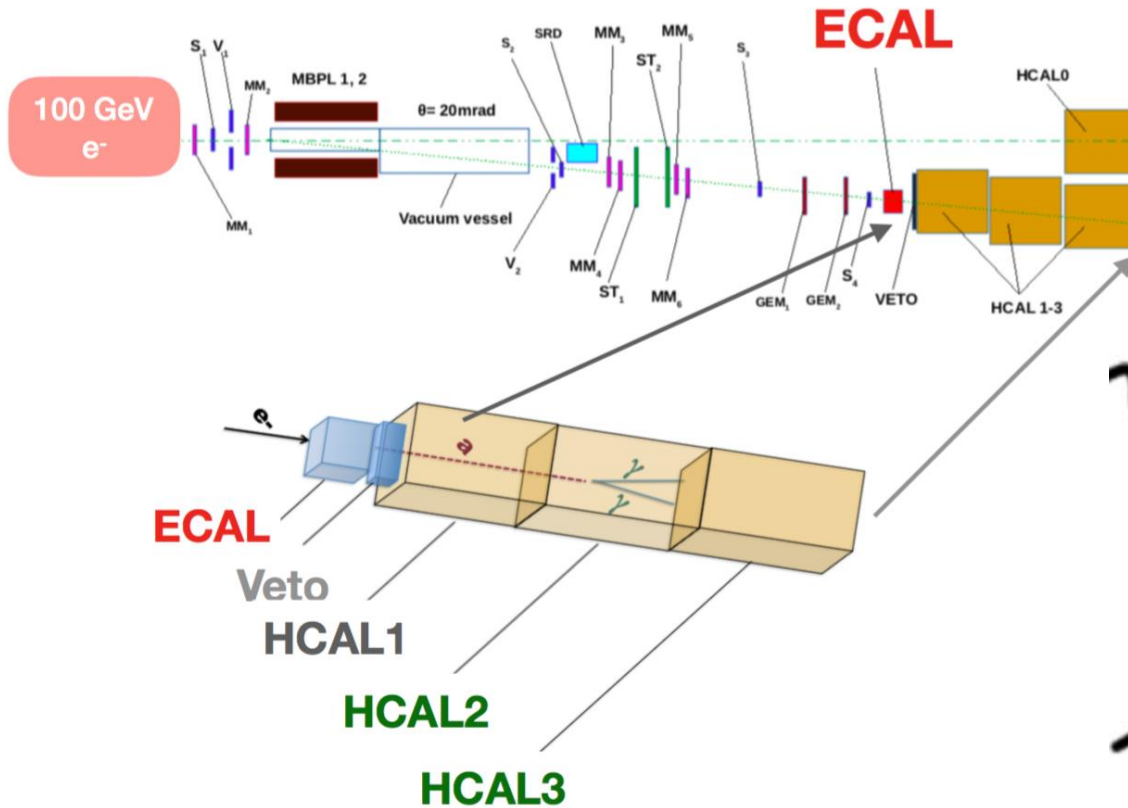

$$L_{int} = -\frac{1}{4} g_{a\gamma\gamma} F_{\mu\nu} \tilde{F}^{\mu\nu} a$$

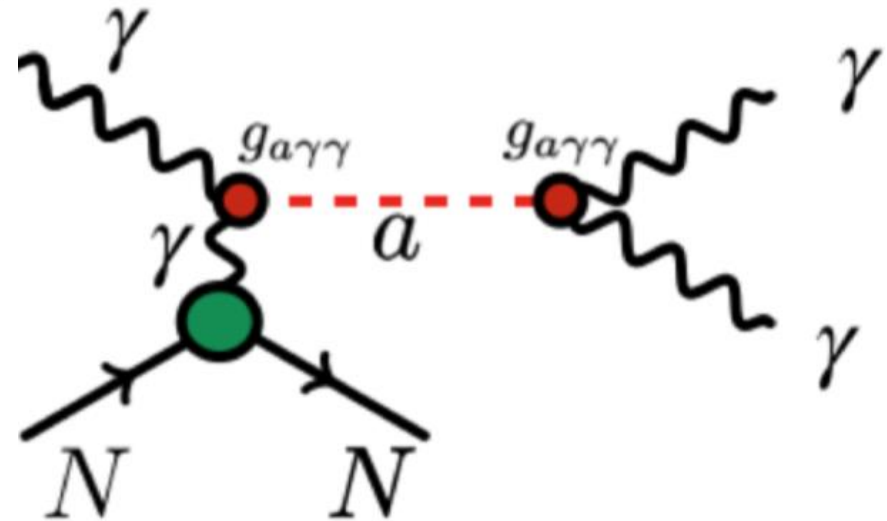



ALP search results (data 2016 – 2018)

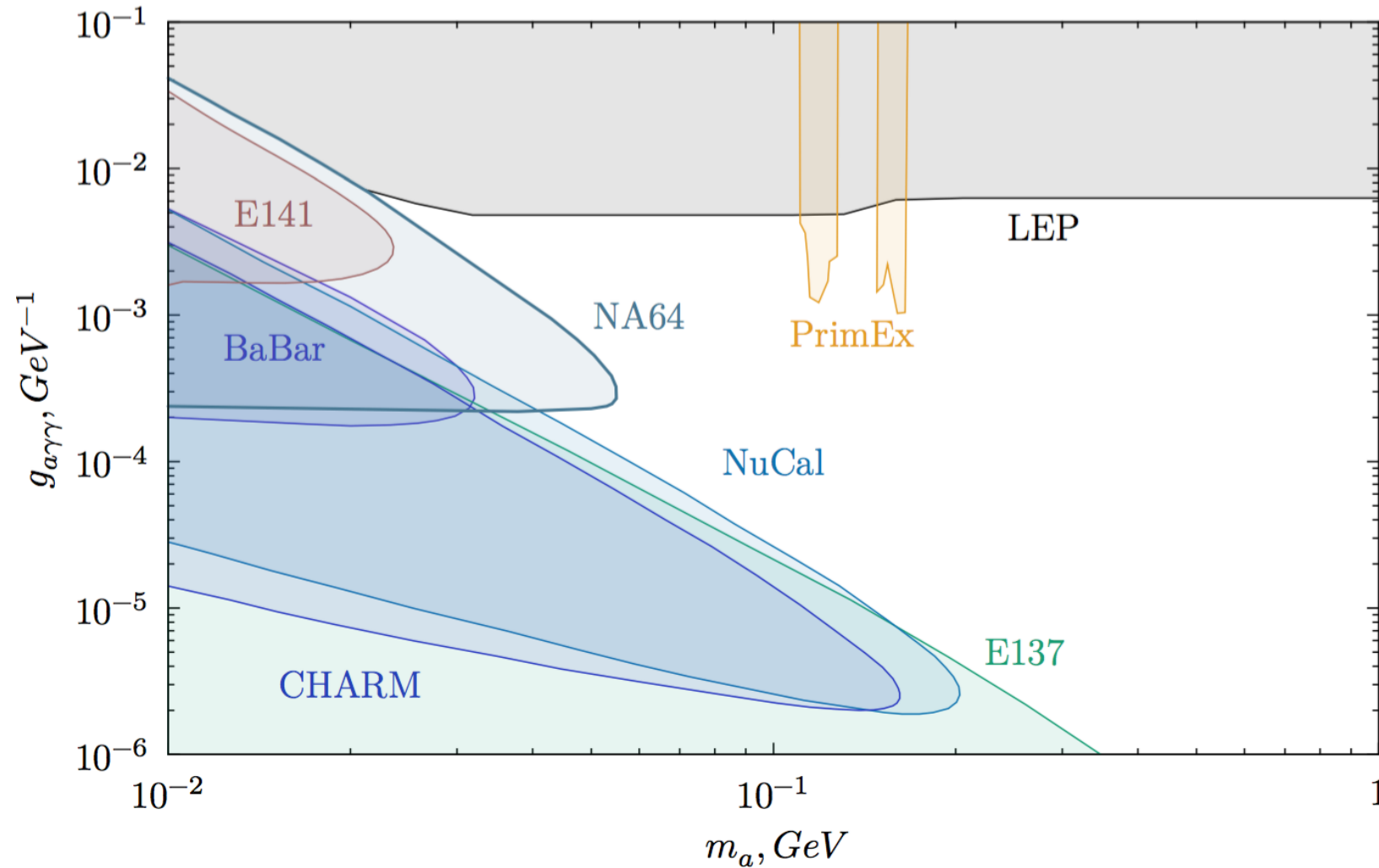

Search for $X(A') \rightarrow e^+e^-$ decays

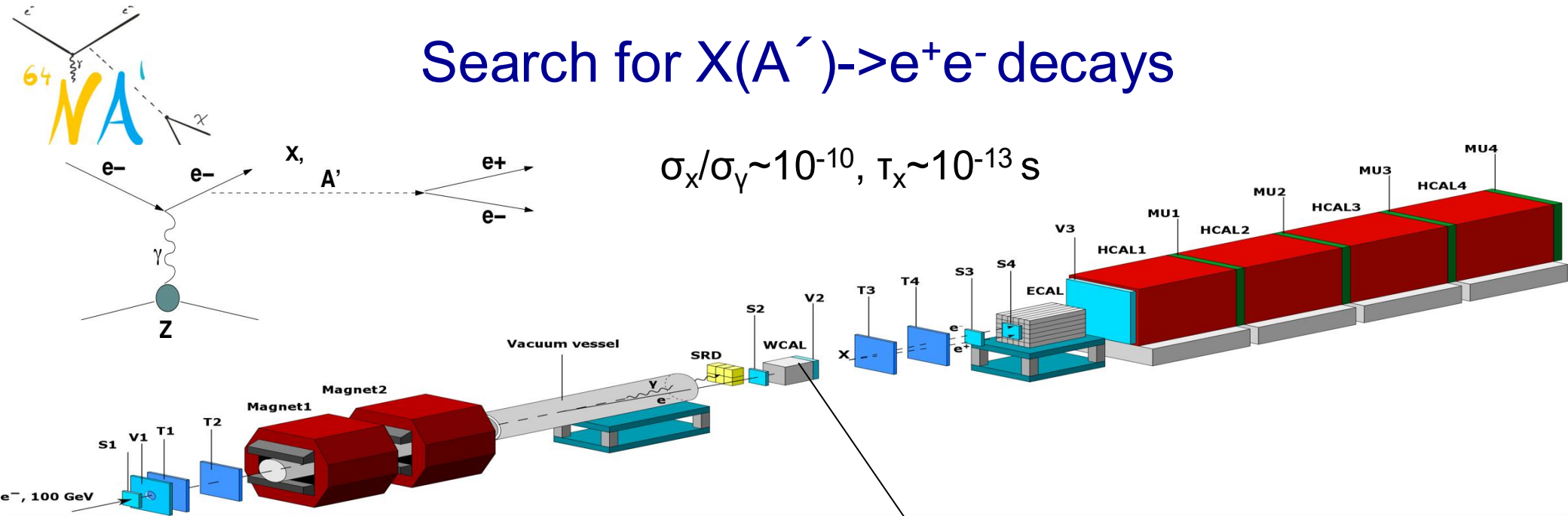

- **Compact tungsten calorimeter**

WCAL

- X decays outside WCAL dump
- **Signature:** two separated showers from a single e^-
 - $E_{WC} < E_0$, and $E_0 = E_{WC} + E_{EC}$
 - $\theta_{e^+e^-}$ too small to be resolved

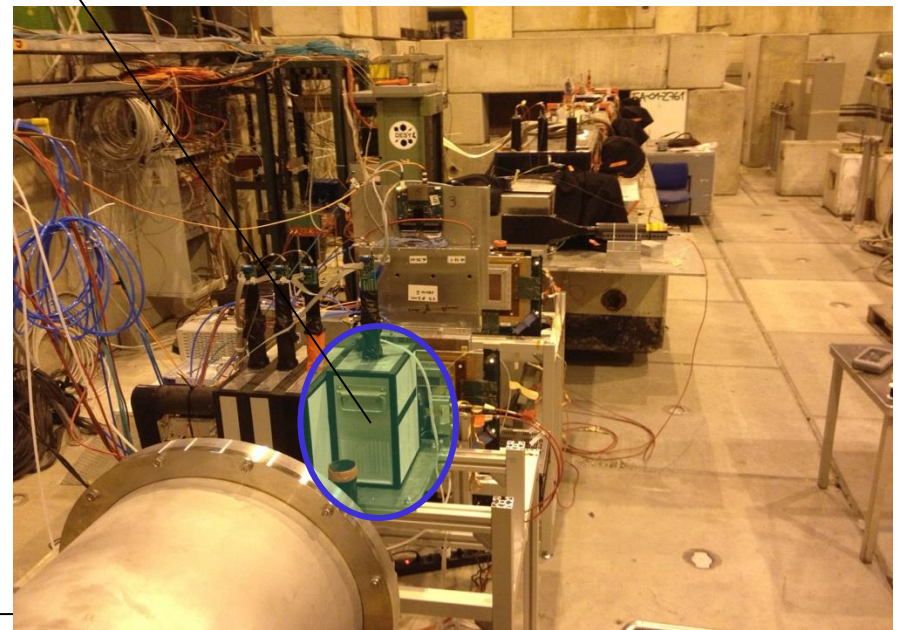



Setup optimization

Second run (2018), with 3×10^{10} EOT was performed with the visible mode configuration optimized for bigger ε (short-lived X) and better background suppression: 150 GeV beam, veto counter inside WCAL box, vacuum decay tube, larger distance WCAL - ECAL

TOP VIEW, 2018 setup

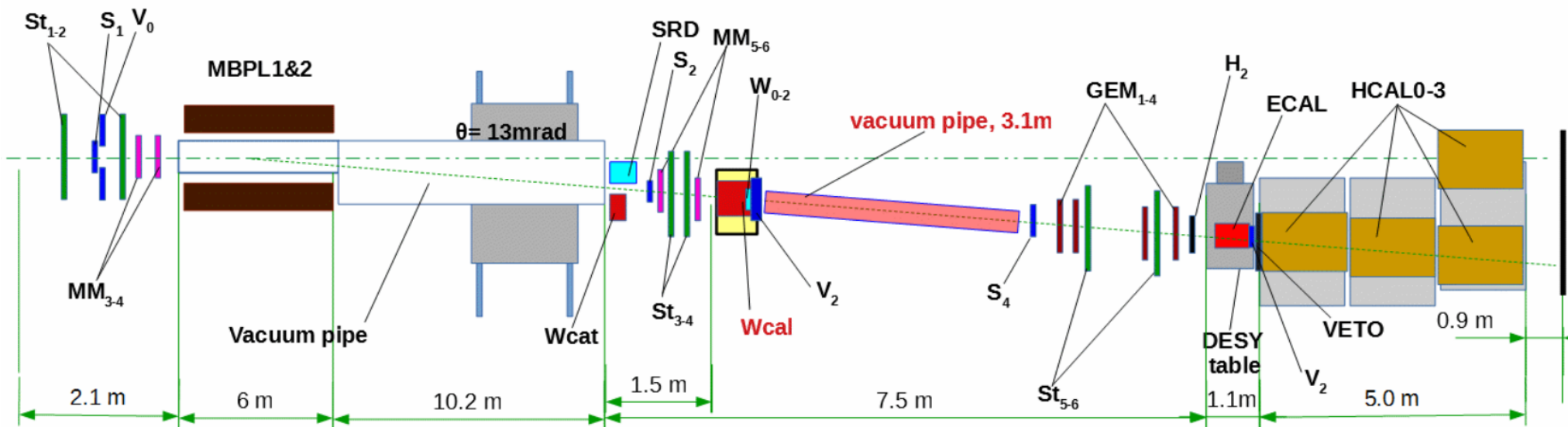



Results with 8.4×10^{10} EOT (+invis. mode data for pseudoscalar)

Later, NA62 excluded axion decaying to e^+e^- : <https://arxiv.org/pdf/2307.04579.pdf>

Vector, PRD 107, 071101 (R) 2020

New: Pseudoscalar, arXiv: 2104.13342 [hep-ex]

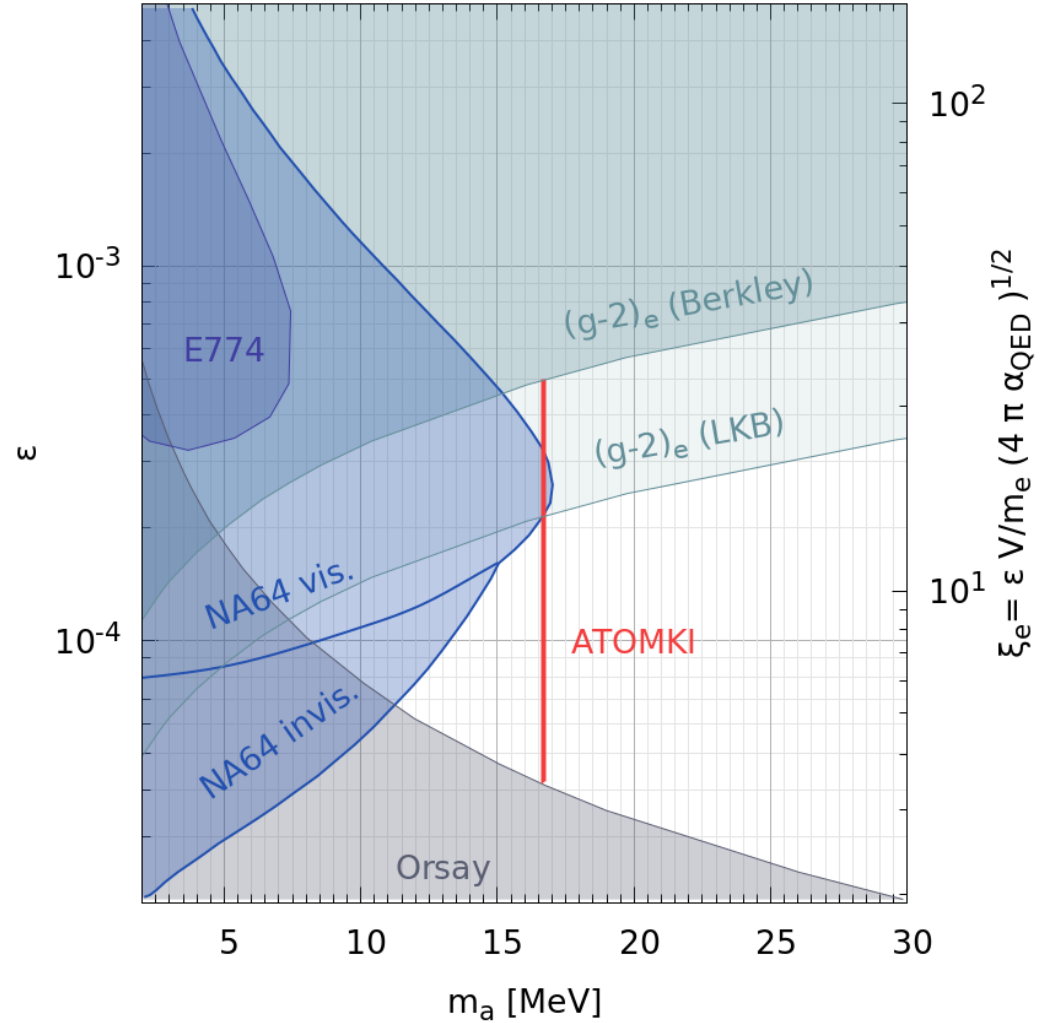
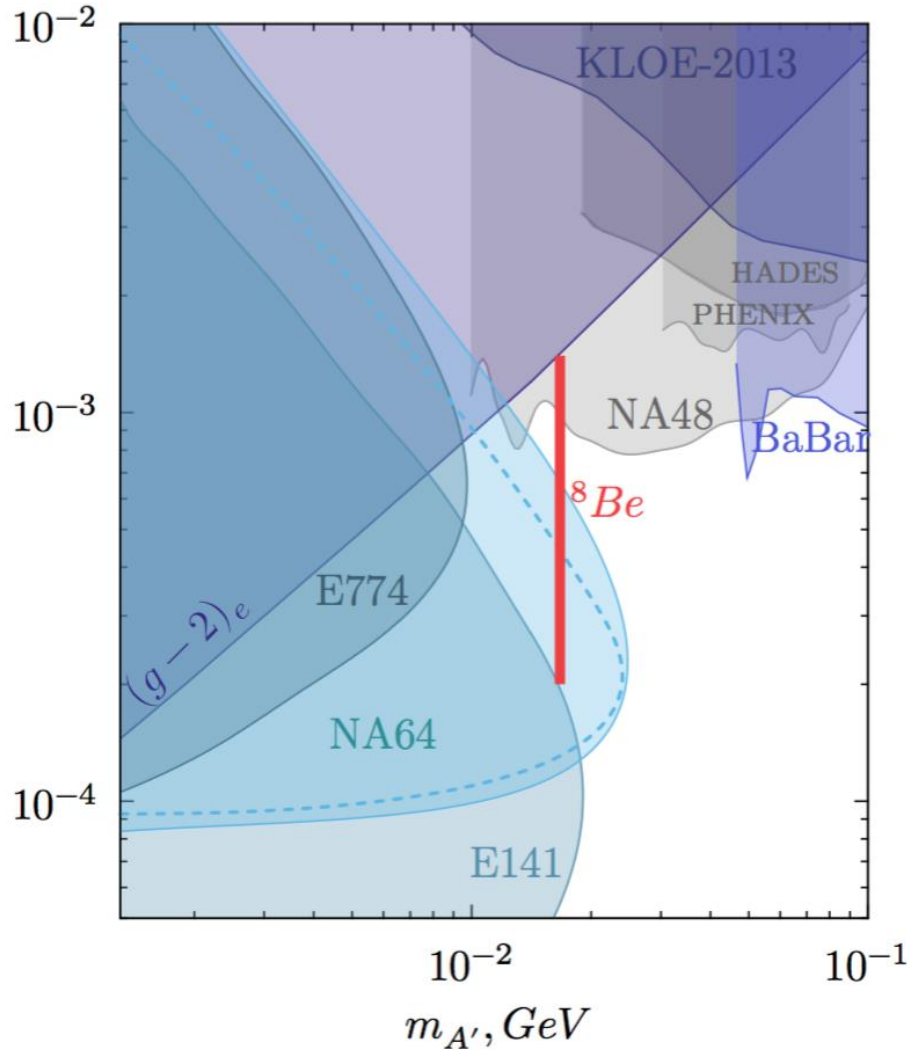



New visible mode projects

- Idea: the bremsstrahlung processes can be enhanced in crystals. Shorter shower, increased probability for X particle to exit from the target.
- 2026 – test at H4
- Further improvement of the visible mode setup: spectrometer, invariant mass reconstruction. Description of this project is published.



NA64 μ

Two stages:

1. Study the possibility to explain the $(g-2)$ anomaly by the new muonphilic WIP
2. Complement the NA64e

L_μ - L_τ Charged Dark Matter and Z_μ mediator

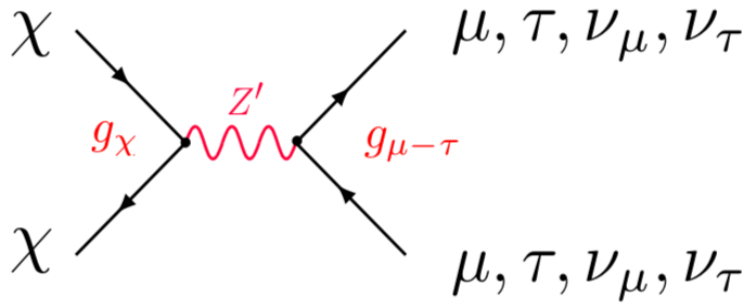
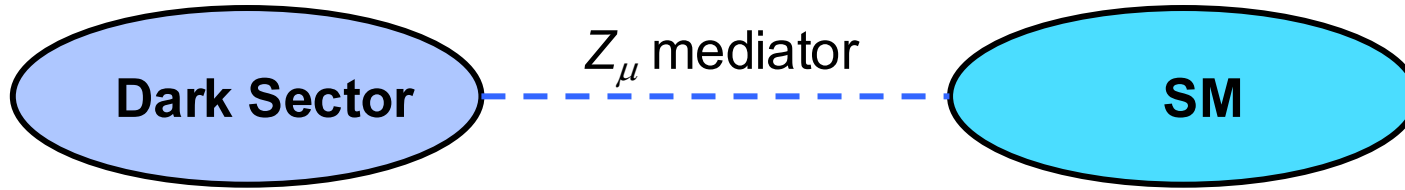

- LDM coupled predominantly to **generations 2,3**
 - free parameters $m_\chi, m_{Z_\mu}, g_\chi, g_\mu$
 - Z_μ decays:
 - $m_{Z_\mu} < 2m_\chi$ - decays into SM, $Z_\mu \rightarrow \nu\nu, \mu^+\mu^-, \tau^+\tau^-$
 - $m_{Z_\mu} > 2m_\chi$ - invisible decays into DM: $Z_\mu \rightarrow \chi\chi, \nu\nu, \alpha_D \gg \alpha_{SM}, \alpha_D = g_\chi^2/4\pi, \alpha_{SM} = g_\mu^2/4\pi$

$$J_\chi^\mu = g_\chi \times \begin{cases} i\chi^* \partial_\mu \chi + h.c. & \text{Complex Scalar} \\ \bar{\chi}_1 \gamma^\mu \chi_2 + h.c. & \text{Pseudo-Dirac Fermion} \\ \frac{1}{2} \bar{\chi} \gamma^\mu \gamma^5 \chi & \text{Majorana Fermion} \\ \bar{\chi} \gamma^\mu \chi & \text{Dirac Fermion} \end{cases}$$

Gninenko, Krasnikov 1801.10448

Kahn, Krnjaic, Tran, Whitbeck 1804.03144

- Cross section for χ -DM annihilation:

$$\Gamma_{\text{inel}} = n_\chi \langle \sigma v \rangle$$

$$\sigma v \text{ H} [(g_\chi g_\mu)^2 (m_\chi/m_{A'})^4] / m_\chi^2 = y/m_\chi^2 ;$$

$$y = [(g_\chi g_\mu)^2 (m_\chi/m_{A'})^4] -$$
 useful variable to compare FTE sensitivities

Search for Z_μ in missing energy events on M2 beam

Motivated by $(g-2)_\mu$ measurements

Proposal NA64 $_\mu$ (2019)

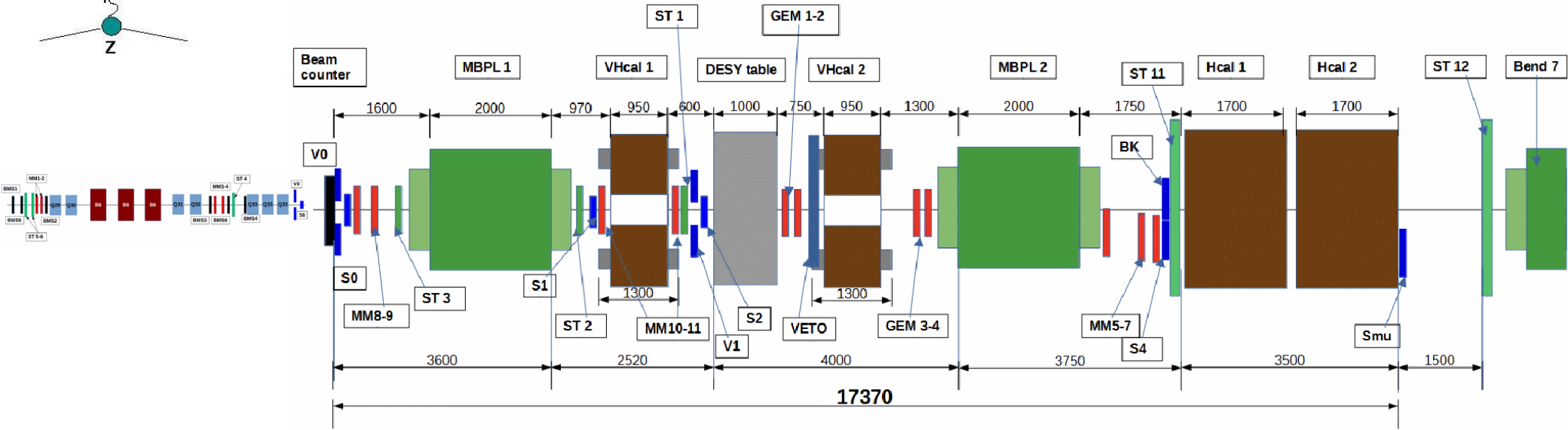
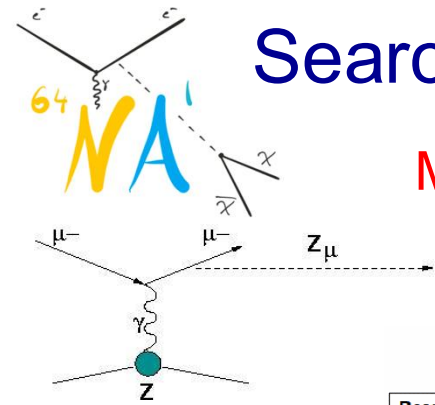

Main components :

- 100-160 GeV μ^- beam, $I_\mu \sim 10^7 \mu/\text{spill}$.
- in μ tagging: BMS+MS1(MBPL+tracker)
- out μ tagging: MS2 (2MBPL+tracker)
- 4π fully hermetic ECAL+Veto+ HCAL

Signature:

- **in:** 160 GeV μ^- track
- **out:** < 80 GeV μ^- track (recoil)
- small energy in the ECAL, Veto, HCAL
- Sensitivity $\sim g_\mu^2$

NA64 μ experiment setup, physics run 2023

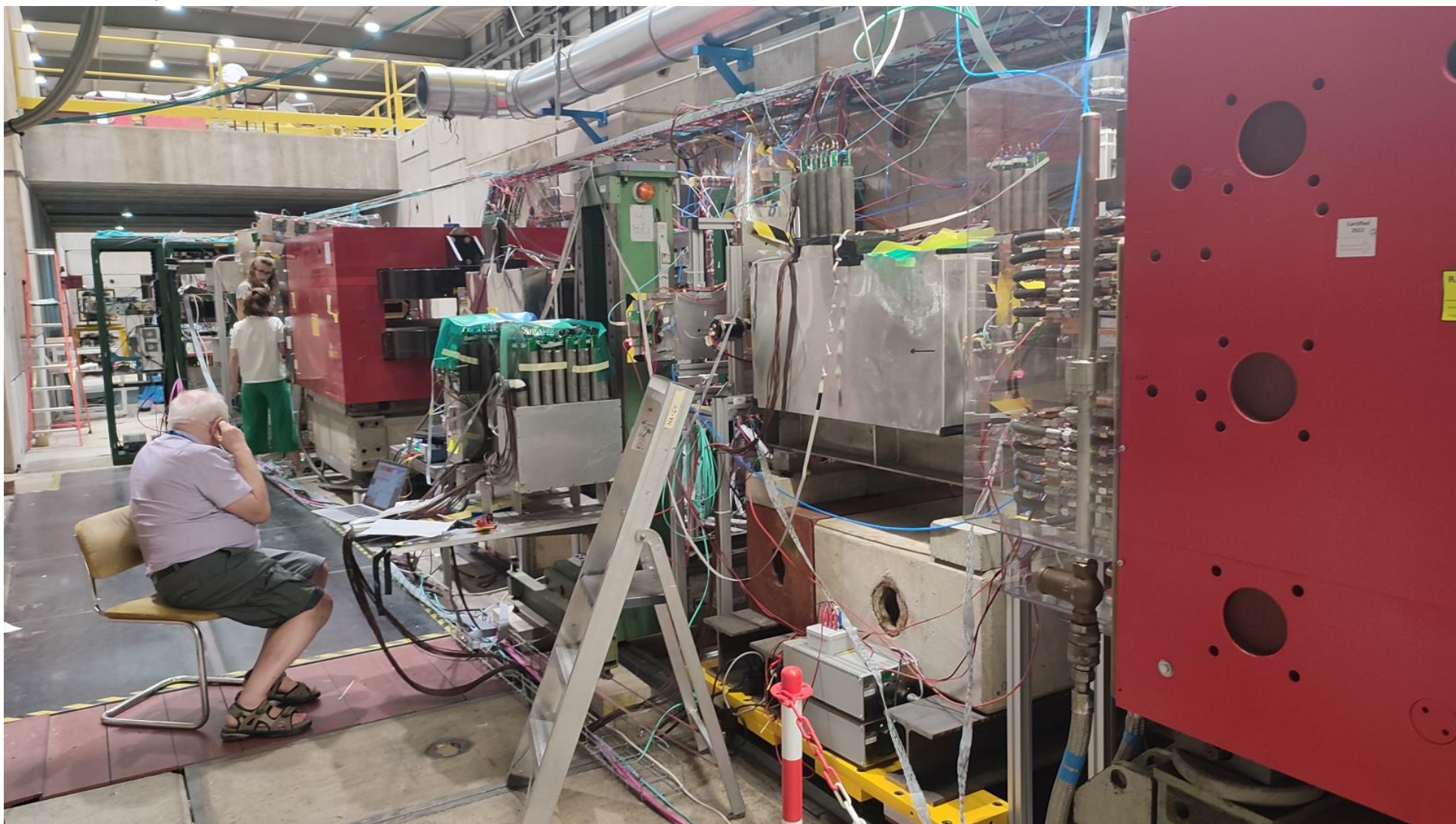



Pilot runs on M2 in 2021 and 2022 are followed by the physics runs

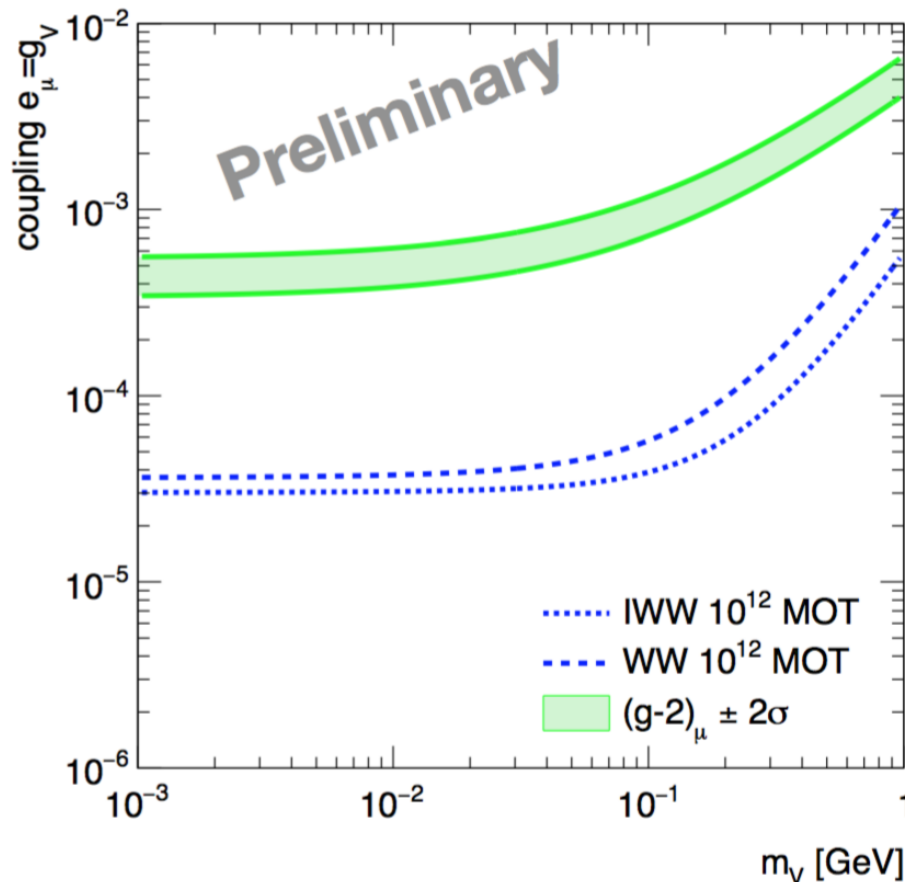

Pilot runs to check trigger rate and noise conditions
 $\sim 4 \times 10^{10}$ MOT

Using the experience from pilot runs we upgraded tracker and performed physics runs in 2023 and 2024: 3.5×10^{11} MOT.
Analysis is ongoing

- New wide HCAL
- New special ECAL



Physical analysis of the 2022 NA64mu data

Phys. Rev. D 110, 112015
(2024)
~2x10¹⁰ MOT

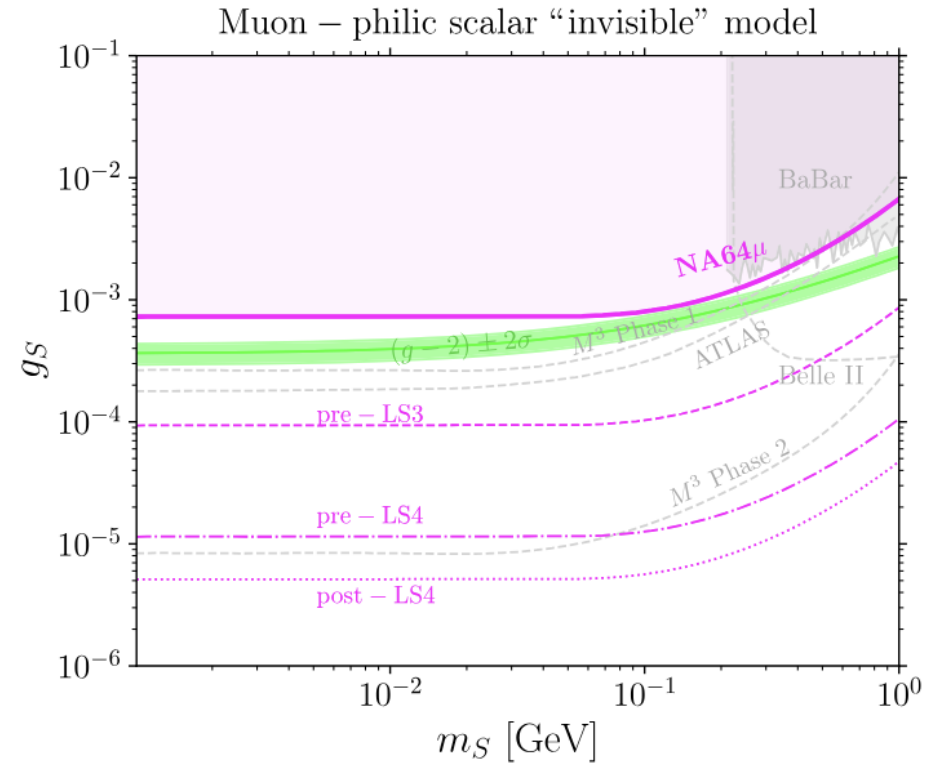
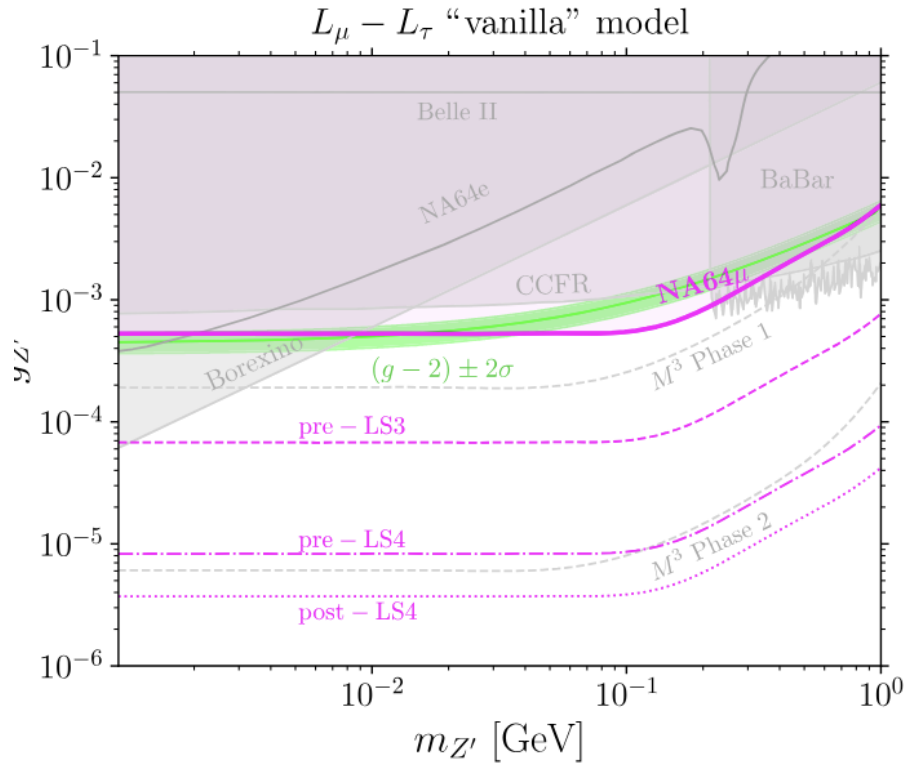



Searches for A' with NA64 μ

Better sensitivity to heavy A' (>100 MeV)

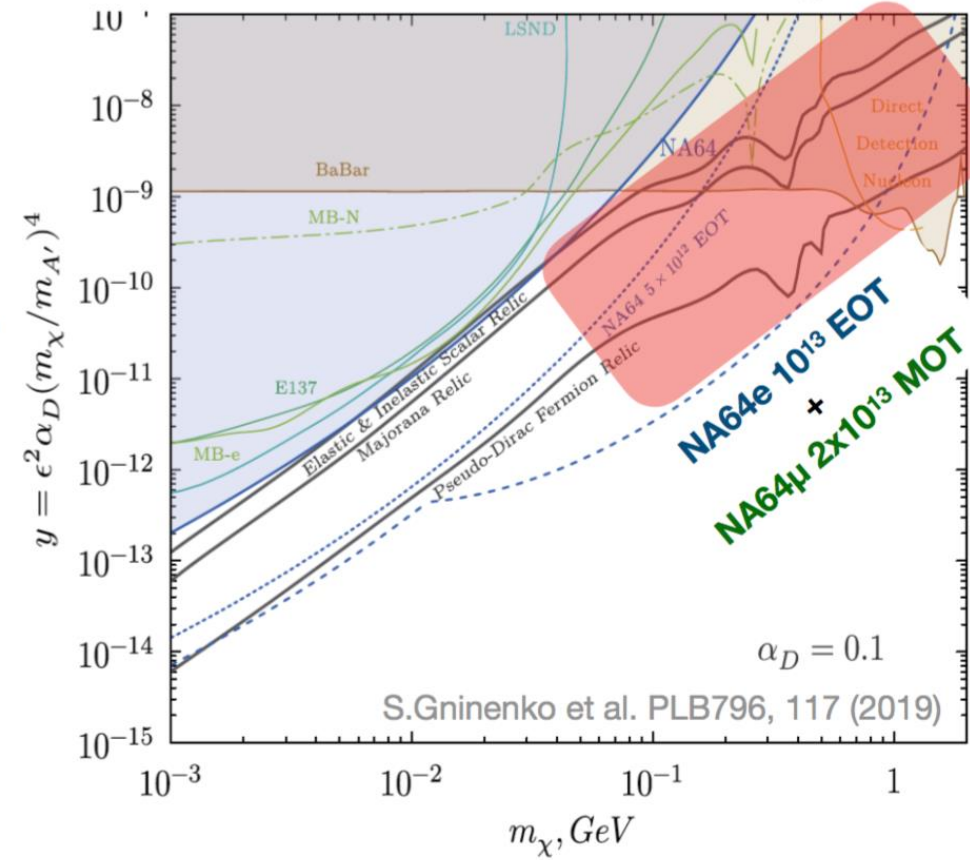
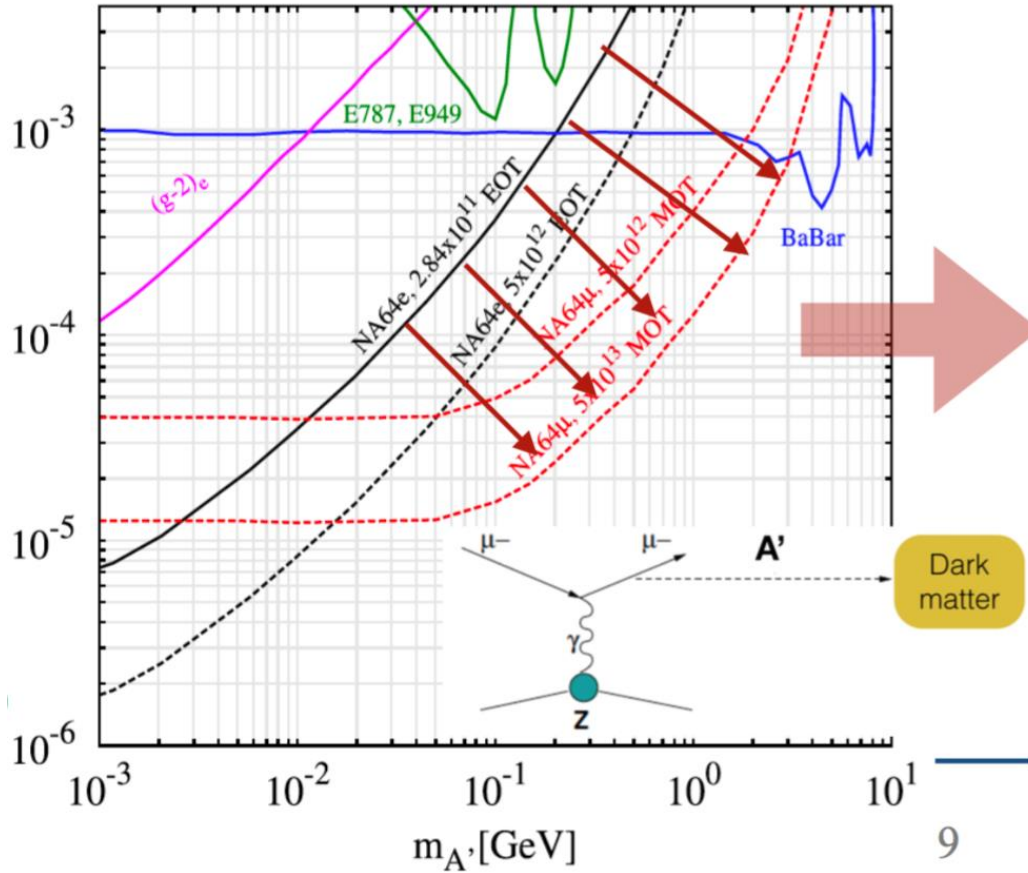



NA64h: Search for dark sector coupled mainly to quarks

(e.g.: π^0 , η , η' , $K^0_{S,L}, \dots \rightarrow$ inv decays)

Run at H4 in 2022 at 50 GeV,

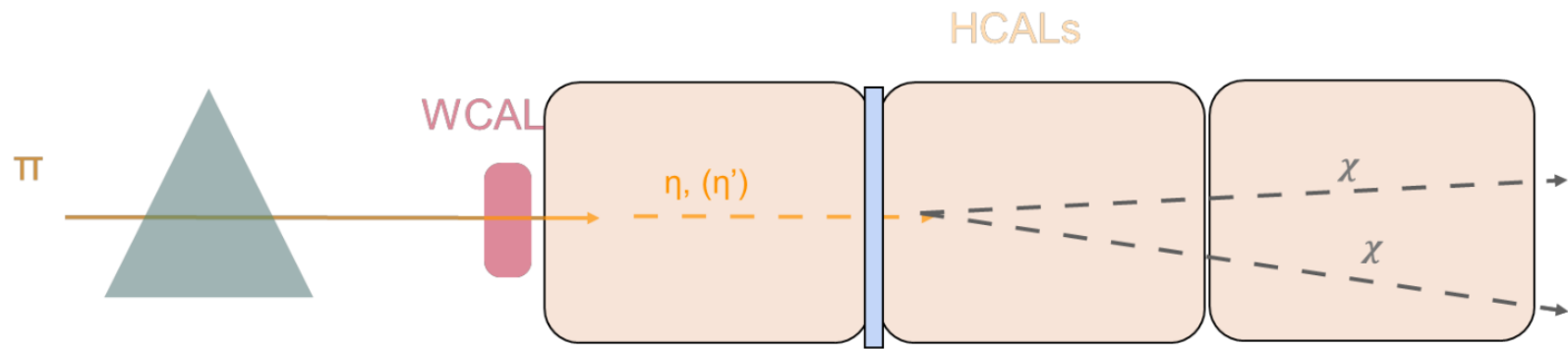

η , η' , K^0 – production:

$\pi(K) Z \rightarrow \eta(K^0) (Z-1)$

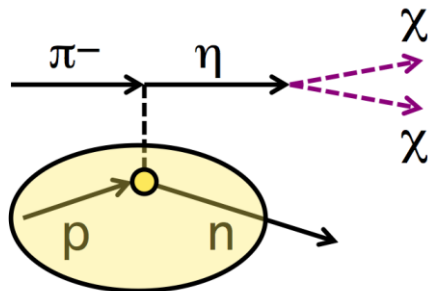

Fe(26,56)

- Single track from 50 GeV p-
- Events with $E_{HC} \approx E_0$ - test NA64mu
 - MIP in WCAL and S
- **Almost no energy in HCAL:** $E_{miss} \sim E_0$
 - BG: π, μ decays $\sim 10^{-11}/pot$
- $Br(\eta \rightarrow inv) < \sim 10^{-5}-10^{-4}$ (BaBar/BESIII)



NA64h: Search for dark sector coupled mainly to quarks

Preliminary

E_{VETO} cut from random trigger

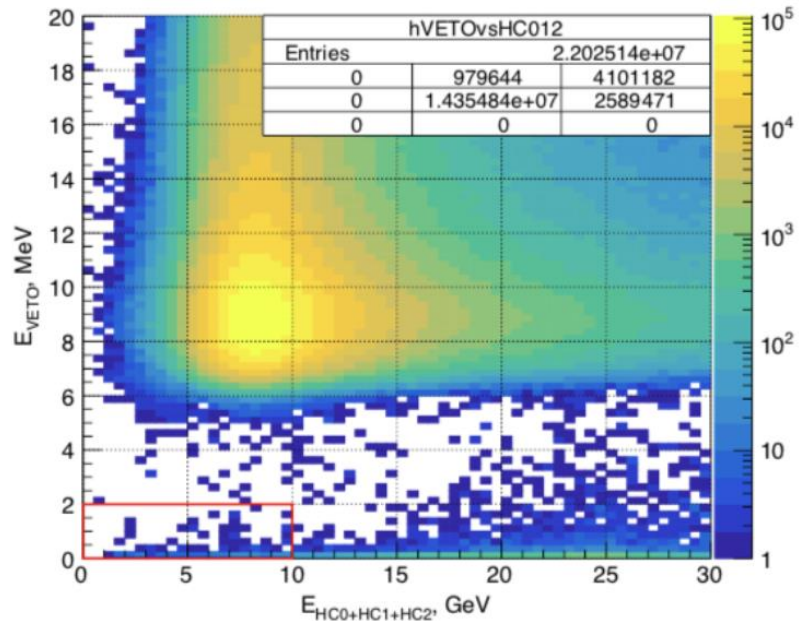

Preliminary

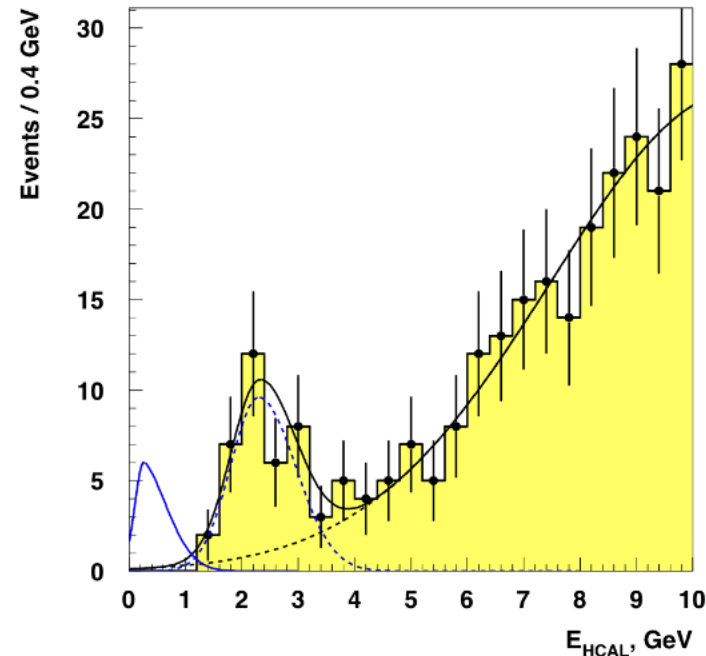

Yellow – BG. Peak at ~ 2.5 GeV is from K^- decays
 Blue curve – signal + noise (from random trigger)



NA64h: Search for dark sector coupled mainly to quarks

Results in *Phys. Rev. Lett.* 133, 121803 (2024)

Preliminary results on $\Gamma/\Gamma_{\text{tot}}$: $\eta : < 1.1 * 10^{-4}$ existing: $1 * 10^{-4}$ (BESIII)

Preliminary results on $\Gamma/\Gamma_{\text{tot}}$: $\eta_{\square} : < 2.3 * 10^{-4}$ existing: $6 * 10^{-4}$ (BESIII)

The results are **dominated** by the uncertainty on the production reaction **cross section** (charge exchange process).

The measurement in the closest region, on Al, Cu at 20 – 48 GeV,
is performed in **IHEP Protvino**



NA64h: New setup in 2025

(e.g.: π^0 , η , η' , $K^0_{S,L}, \dots \rightarrow$ inv decays)

Run at H4 at 50 GeV

η , η' , K^0 – production:

$\pi(K) Z \rightarrow \eta(K^0) (Z-1)$

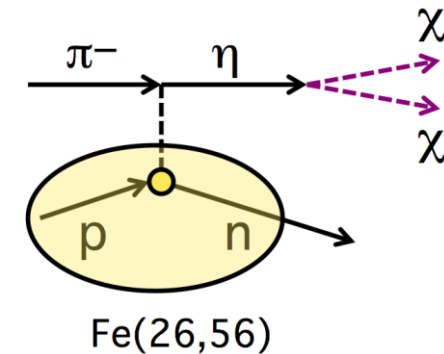

Cerenkov counters ID

Preliminary:

First result on K^0 ?

2025 hadron

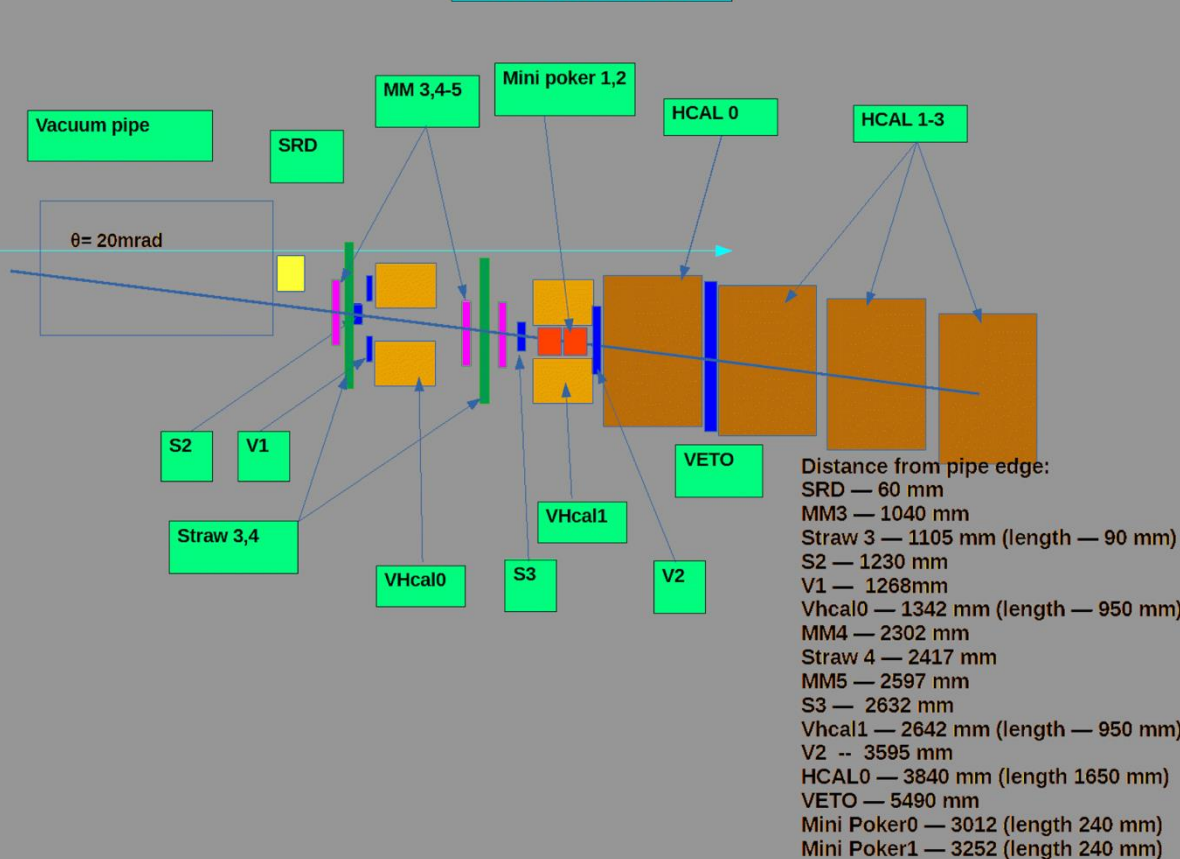

Summary



- The NA64 experiment produced several important results in the search for light Dark Matter (LDM, sub-GeV mass range) coupled universally to leptons and quarks. With the milestone statistics of $\sim 10^{12}$ EOT it provides the world-leading constraints on the benchmark LDM models
- The plan is to significantly increase the sensitivity and maximally cover the regions of predictive **thermal Dark Matter** models
- One of the possibilities to improve sensitivity is to use **positron beam** (POKER project)
- The **NA64 μ** experiment started in 2021. The purpose is to obtain more direct answer to the question about the $(g-2)_\mu$ explanation by Dark Matter and to improve sensitivity to A' for the masses > 100 MeV (complementarity)
- The searches for **X(17)** particle that could explain **ATOMKI anomaly** : work on new projects
- **NA64h**: the proof-of-concept in 2022, continued in 2025.
- Two test runs at the PS beam are performed: possibility to work during LS3
- Other planned searches are **$\mu - \tau$ conversion**, **LFV DM production**, **K0 oscillations to DM** etc.



Backup slides

Backup



Dimuon production as a reference process

- There is an excellent reference process: **gamma to muons conversion**. It is rather rare and has many similarities with our signal
- Millions of dimuon pairs with both muons reaching all HCAL modules are registered in NA64
- The process is available in GEANT4, off by default
- We bias the cross section in GEANT4 by a factor of 200 in order to have good statistics with reasonable CPU time.
- Reasonable agreement DATA - MC

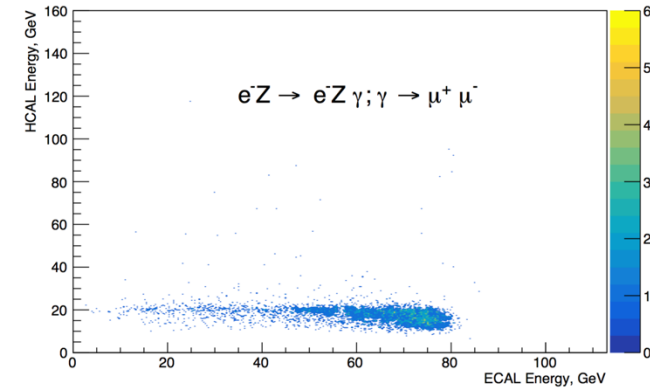

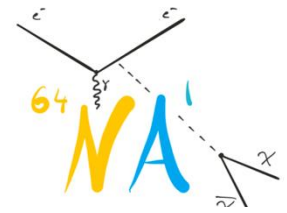

Dimuon reconstruction

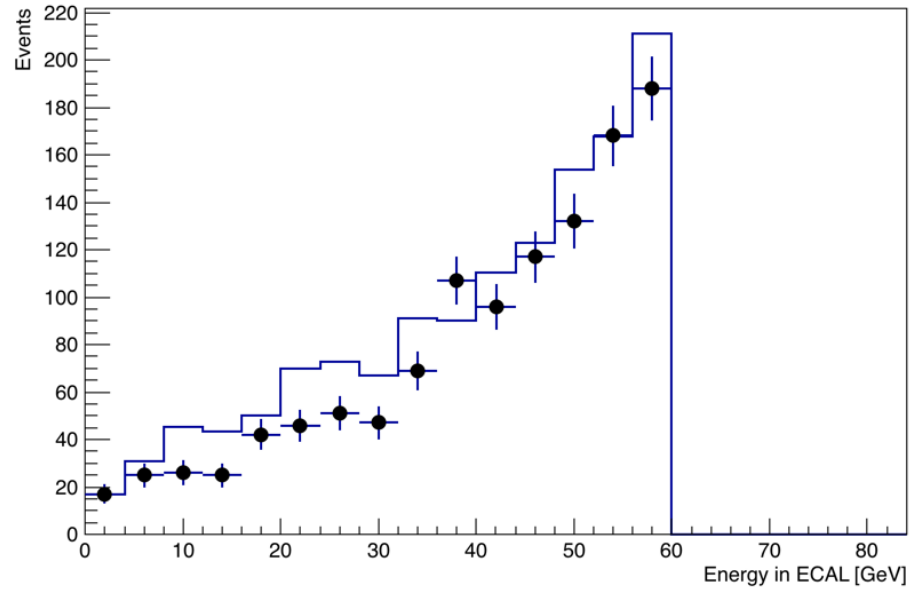

Dimuons selection: $E_{\text{ECAL}} < 60 \text{ GeV}$
 $3 < E_{\text{HCAL1}} < 7$
 $3 < E_{\text{HCAL2}} < 7$



ALP search strategy

- In addition to invisible decays beyond the detector (missing energy signature) look for decays in **HCAL2**, **HCAL3** with HCAL1 as a veto
- Allows softer cuts on energy deposition in ECAL
- **Background:** punch-through neutrons and K^0
- Final cut on **$R = (\text{periphery cells})/(\text{central cell})$** , strong suppression of hadrons



Search for new X-bosons and Dark Photons decaying to e^+e^-

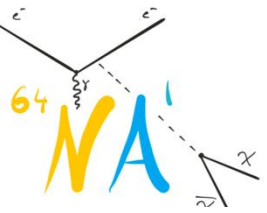

ATOMKI anomaly

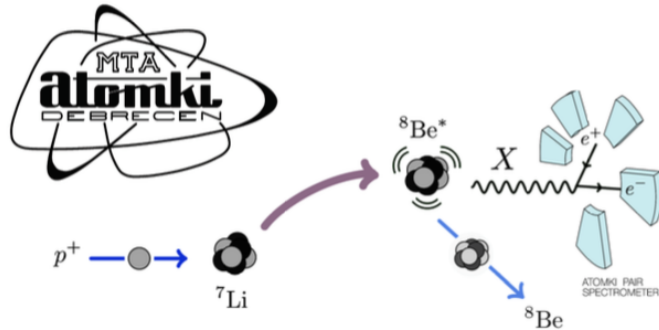

- Scalar, pseudo-scalar, vector, axial-vector models could explain the anomaly (large literature)
- NA64 addresses the search for X17 in a model independent way, just assuming its non-zero coupling with electrons.
- Vector model used as benchmark.

$$e^-Z \rightarrow e^-ZX_{17}; X_{17} \rightarrow e^+e^-$$

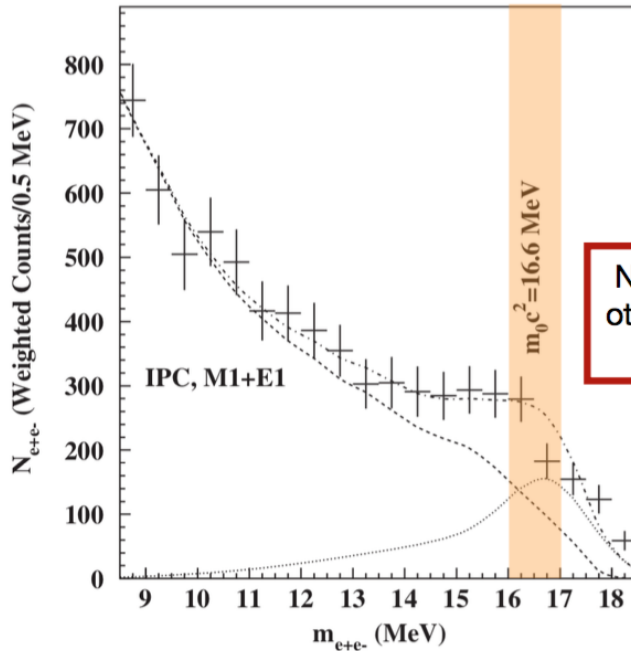

A.J. Krasznahorkay et al. Phys. Rev. Lett.116, 042501 (2015)

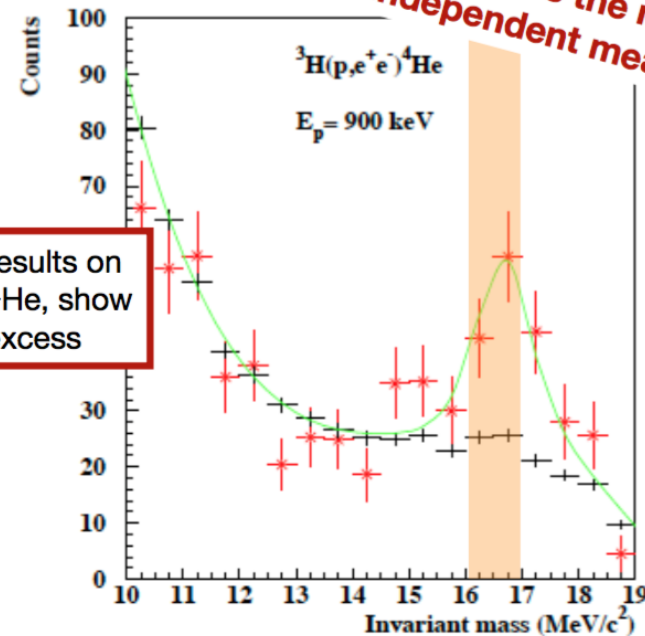

New recent results on other nuclei, ^4He , show a similar excess

Motivates the need of an independent measurement

A. J. Krasznahorkay et al. Arxiv:1910.10459 (2019)



Main background from $K_S^0 \rightarrow \pi^0 \pi^0 \rightarrow \gamma \square s \rightarrow e^+e^-$ decay chain

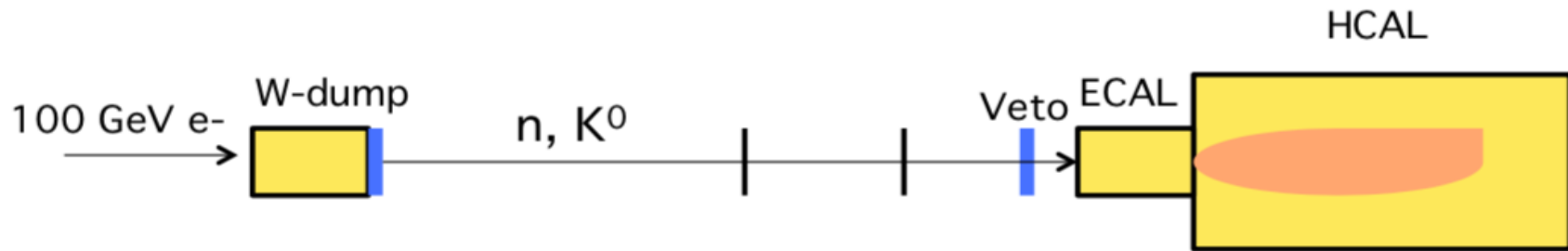

We used **control sample** to estimate this BG: **fully neutral events**

We performed also a search for **pseudoscalar bosons**. Here, we used also data collected in the invisible mode configuration, similarly to the ALP search

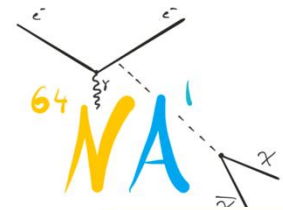

Plans for the visible mode (2024?)

Full parameter space Invariant mass reconstruction

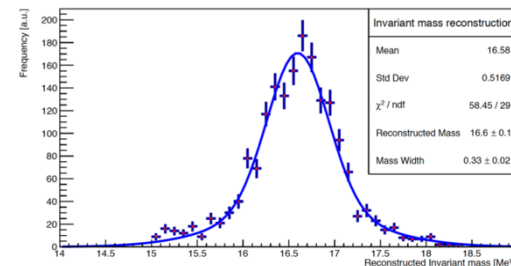
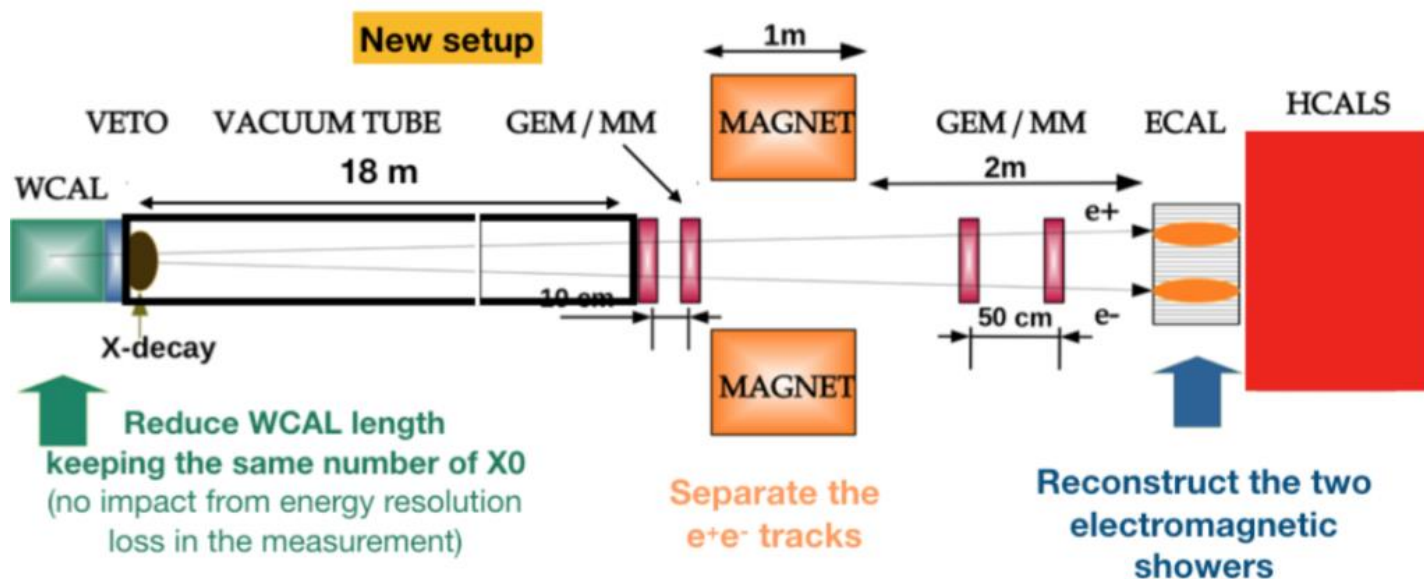

For vector:
cover ϵ up to
 1.3×10^{-3}
with 10^{12} EOT

- New further optimized tungsten calorimeter WCAL
- Long decay tube
- Large area M
- Wide ECAL

Project described in
EPJ C 80 12 1159 (2020)