

# **From TAIGA-1 to TAIGA-100 for PeV gamma astronomy.**

**N. Budnev, L. Kuzmichev For TAIGA collaboration**

**RSF Grant 23-72-00016**

# More than 100 years have passed since Victor Hess discovered "penetrating radiation" coming from space.

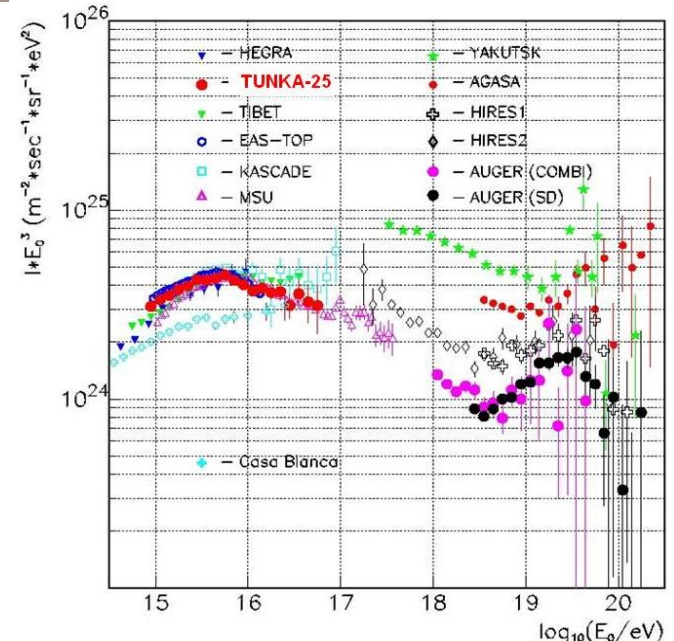
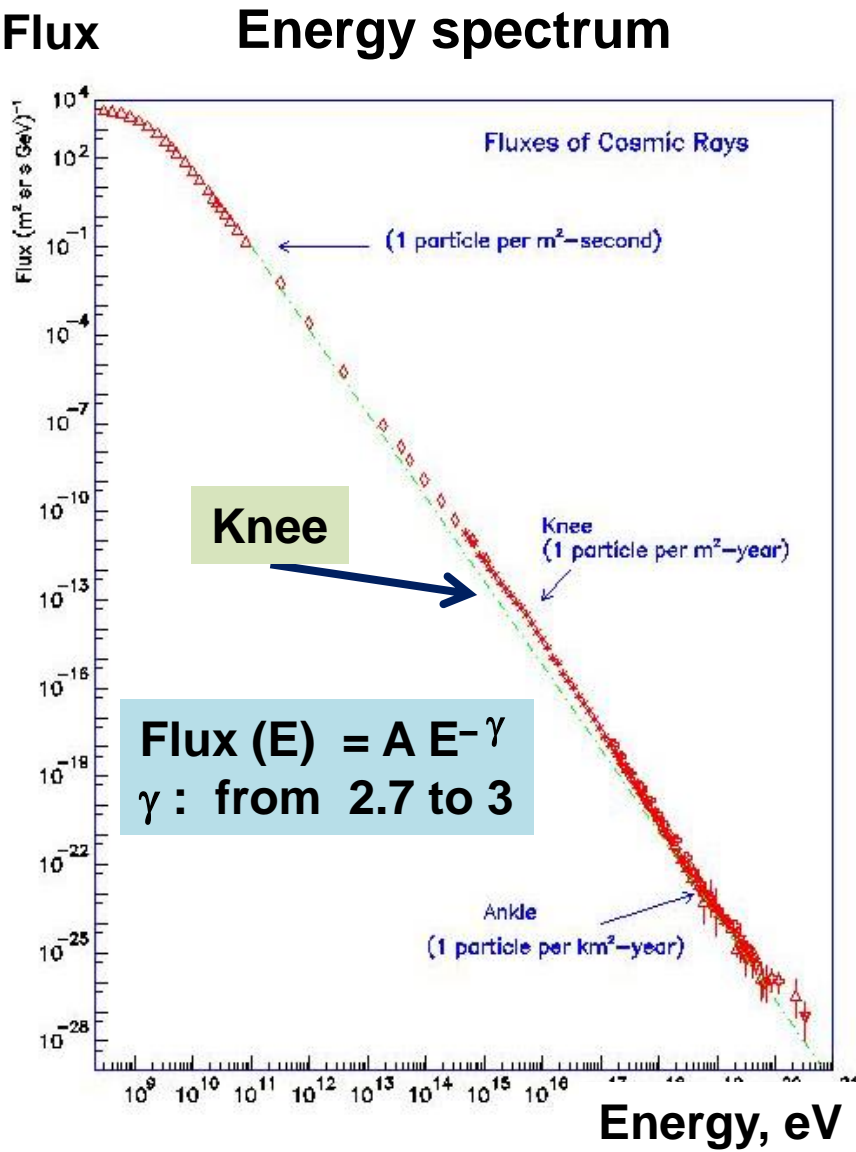

# Gamma-astronomy & neutrino astronomy

To understand a nature of cosmic high energy accelerators should be detected gamma-rays and neutrinos.

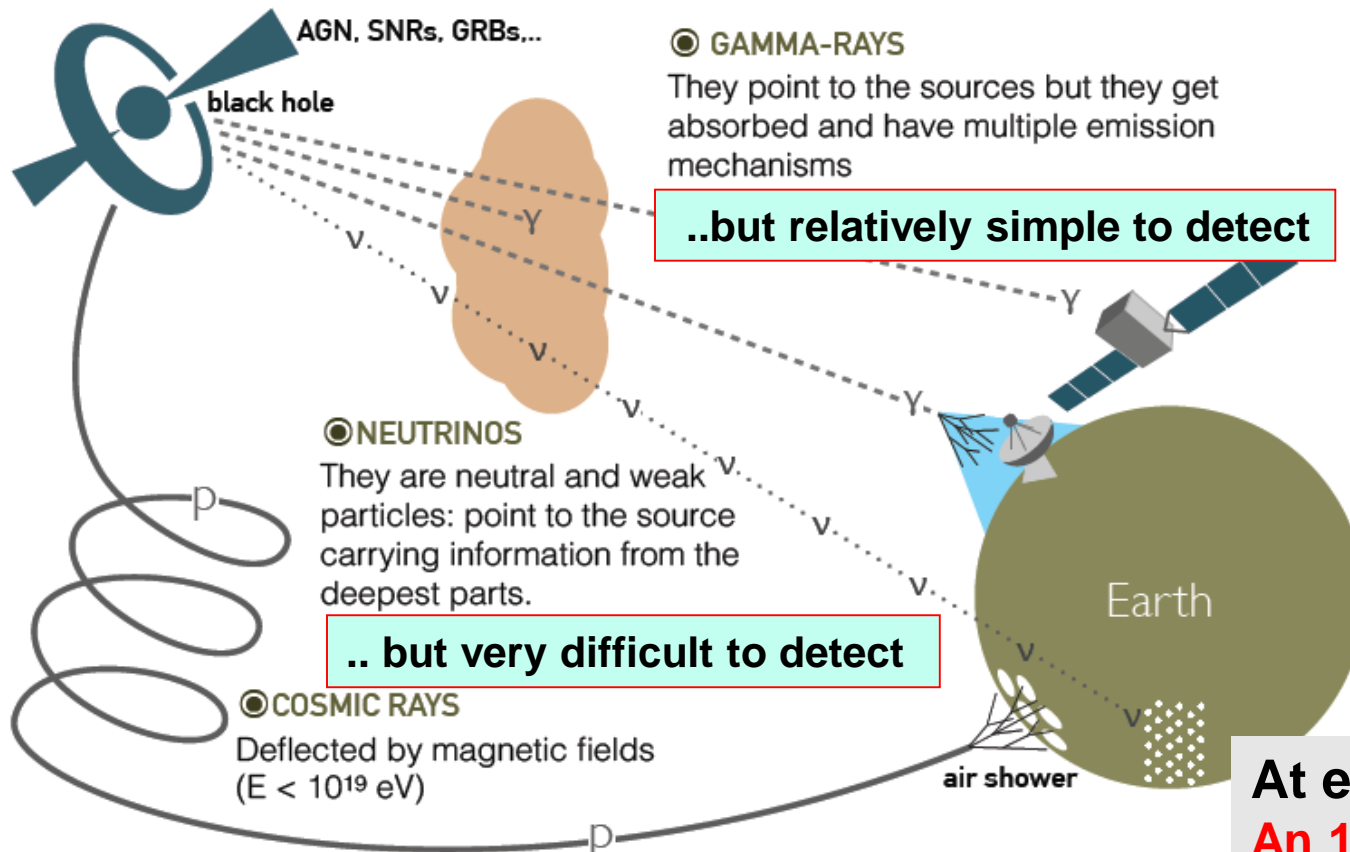

**RX J1713.7 –  
remnant of a super-  
nova**

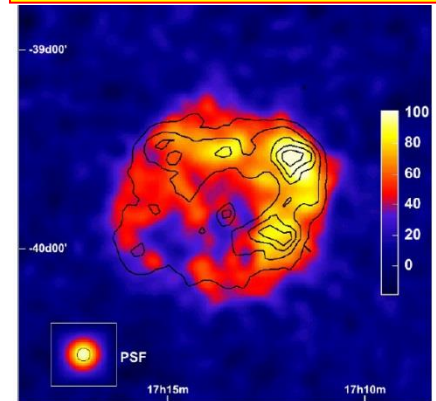

**At energy  $> 30$  TeV**  
**An  $1\text{km}^3$  neutrino detector**  
**- 1 event / 1 year**  
**An  $1\text{km}^2$  gamma detector**  
**- 1 event / 20 minut!**

# Imaging Atmospheric Cherenkov Telescopes (IACT) - as instruments for the ground based gamma astronomy

Whipple  
HEGRA  
H.E.S.S.  
MAGIC  
VERITAS  
 $S < 0.1 \text{ km}^2$

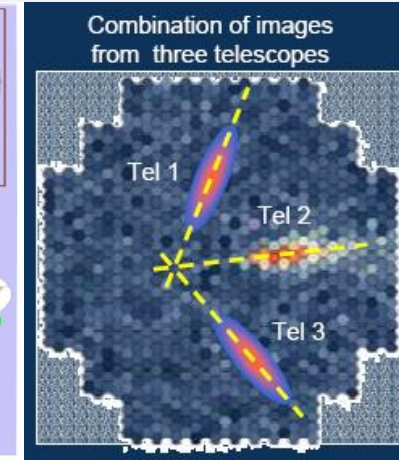
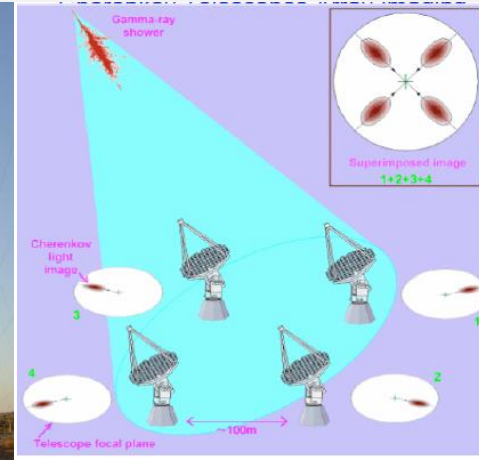
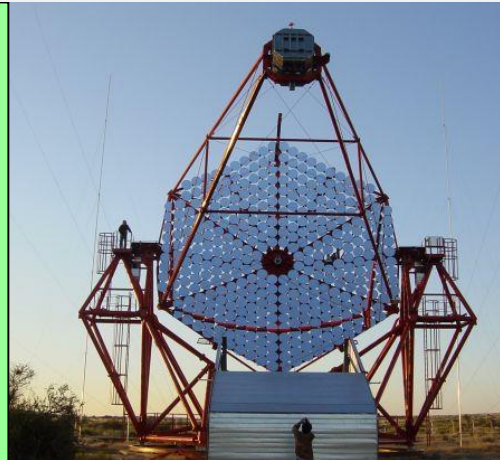

More than 200 sources of gamma rays with energy more than 1 TeV were discovered with IACT arrays. But, due to the small size of the effective area, only a few photons with energies greater than 50 TeV have been detected using IACT to date.

**An area of an array should be  $1\text{m}^2$  as minimum for High Energy Gamma Astronomy .**

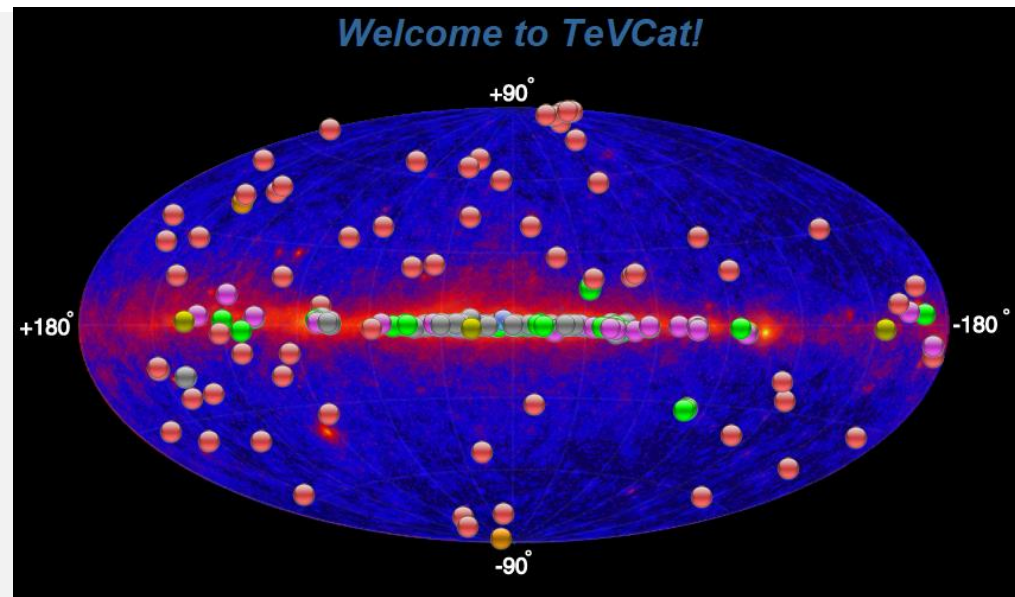

**It is too much expensive with IACT!**

# High-altitude installations



**LHAASO: 1 km<sup>2</sup>, 5200 scintillation detectors, 1200 water muon detectors.**

**HAWC: 0.02 km<sup>2</sup>, 300 water tanks**

**Tibet: 0.06 km<sup>2</sup>, 64 water muon detectors (1/20 LHAASO)**

**LHAASO:**

**Discovery of “PeVatrons” - sources of photons with  $E > 100 \text{ TeV}$**

# The TAIGA (Tunka Advanced Instrument for Gamma Astronomy and cosmic ray physics)

**The main goal:** to find a cost-effective way to create a large-scale installation for high-energy gamma-ray astronomy by combining wide-angle Cherenkov detectors with several relatively cheap small-sized Imaging Atmospheric Cherenkov Telescopes and particle detectors.

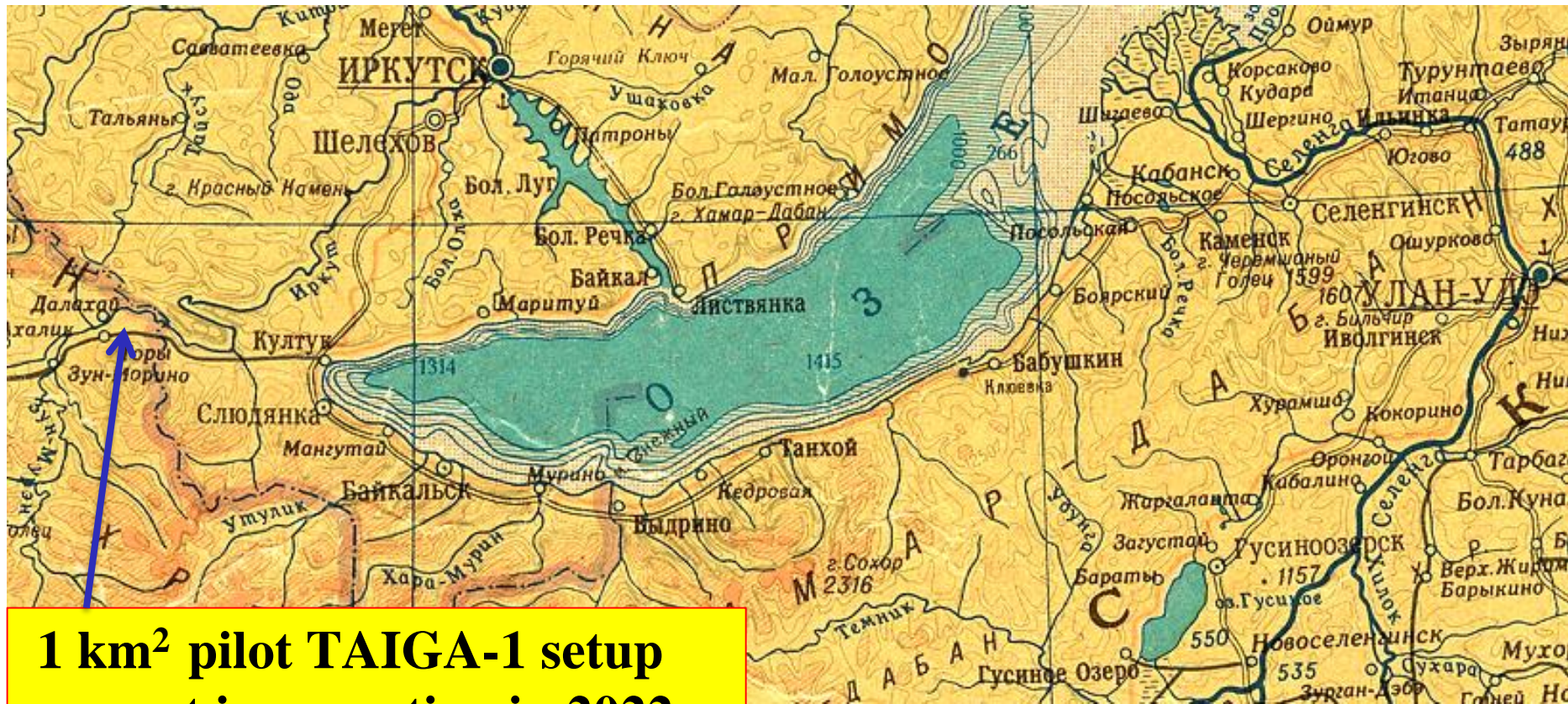

**1 km<sup>2</sup> pilot TAIGA-1 setup  
was put in operation in 2022y.**

# TAIGA-HiSCORE (High Sensitivity Cosmic Origin Explorer)

consist of 120 Cherenkov stations distributed on 1,1 km<sup>2</sup> area with spacing 106 m. In each station there are four 8 inch PMTs equipped with a Winston cone. The total light collection area of a station is 0.5 m<sup>2</sup>. Threshold for CR is 100 TeV, for  $\gamma$ - 50TeV

1. Accuracy positioning EAS core - 5 -6 m
  2. Angular resolution  $\sim$  0.1 – 0.4 deg
  3. Energy resolution  $\sim$  10 - 15%
  4. Accuracy of  $X_{\max}$  measure  $\sim$  20 -25 g/cm<sup>2</sup>
  5. Large Field of view:  $\sim$  0.6 sr
- Total cost  $\sim$  2 · millions \$ (for 1 km<sup>2</sup>)**

Cosmic-ray / gamma-ray

Cherenkov light cone

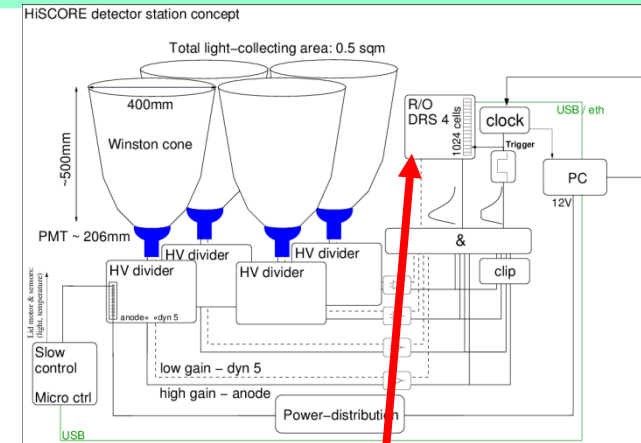
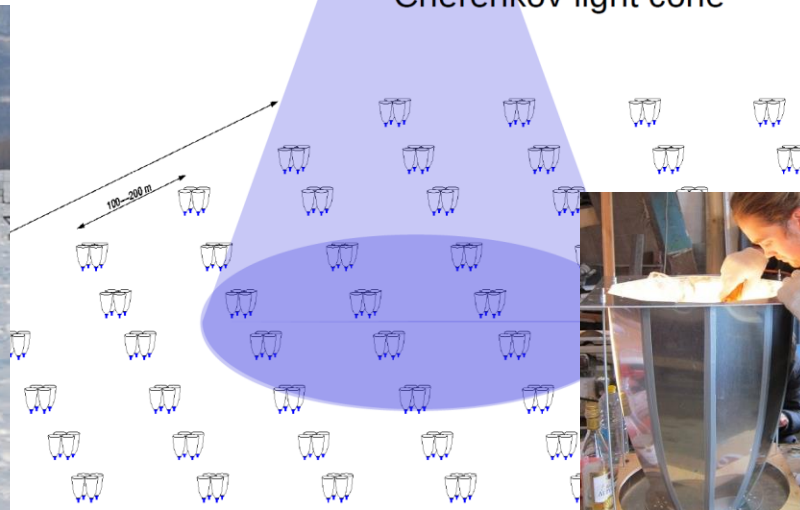

**DRS-4 board ( 0.5 ns step)**

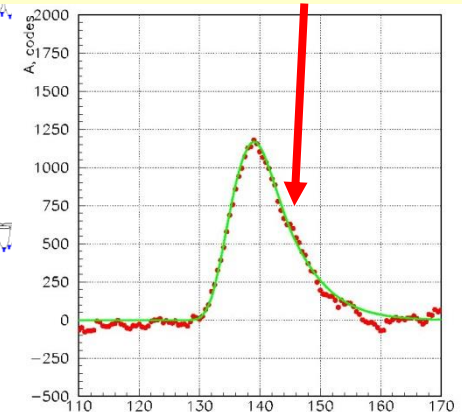

# The TAIGA – IACT

**First IACT - 2017,**

**Second IACT - 2019,**

**Third IACT - 2022,**

**Fourth IACT - 2025**

- **34-segment reflectors (Davis-Cotton)**
- **Diameter 4.3 m, area  $\sim 10 \text{ m}^2$**
- **Focal length 4.75 m**
- **Camera - 600 PMT,  $9.6^\circ$  FoW**
- **Threshold energy  $\sim 2 - 3 \text{ TeV}$**



# IACT & wide-angle Cherenkov detectors of the TAIGA-1 facility.

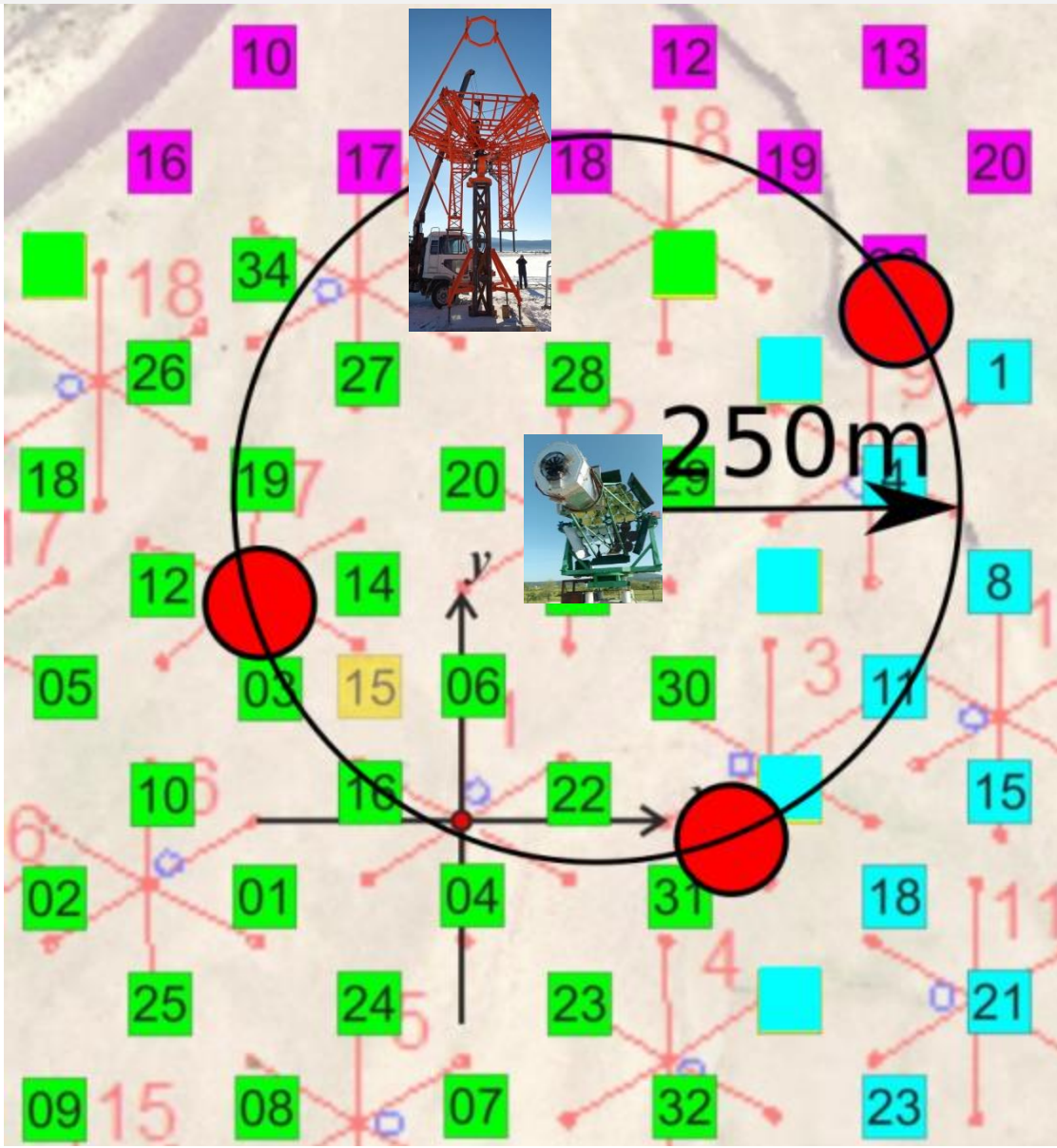

# TAIGA – Collaboration

since 2013y



-  **Irkutsk State University (ISU), Irkutsk, Russia**
-  **Scobeltsyn Institute of Nuclear Physics of Moscow State University (SINP MSU), Moscow, Russia**
-  **Institute for Nuclear Research of RAS (INR), Moscow, Russia**
-  **Institute of Terrestrial Magnetism, Ionosphere and Radiowave Propagation of RAS (IZMIRAN), Troitsk, Russia**
-  **Joint Institute for Nuclear Research (JINR), Dubna, Russia**
-  **National Research Nuclear University (MEPhI), Moscow, Russia**
-  **Budker Institute of Nuclear Physics SB RAS (BINP), Novosibirsk, Russia**
-  **Novosibirsk State University (NSU), Novosibirsk, Russia**
-  **Altay State University (ASU), Barnaul, Russia**
  
-  **Deutsches Elektronen Synchrotron (DESY), Zeuthen, Germany**
-  **Institut für Experimentalphysik, University of Hamburg (UH), Germany**
-  **Max-Planck-Institut für Physik (MPI), Munich, Germany**
-  **Fisica Generale Universita di Torino and INFN, Torino, Italy**

# **The main tasks for the TAIGA-1 complex**

- Studying cosmic rays in the energy range of  $10^{14}$ - $10^{18}$  eV, with an emphasis on the mass composition and energy spectrum in the region of the first and second knee**
- Studies of galactic PeVatrons using TAIGA-IACTs and the TAIGA-HiSCORE facilities.**
- Search for TeV-range gamma-rays from GRB, as well as gamma-rays associated with energetic neutrinos detected by the Ice-Cube and Baikal-GVD neutrino telescopes.**
- Testing the detectors of the TAIGA-100 installation**

**High energy cosmic ray physics,  
some results.**

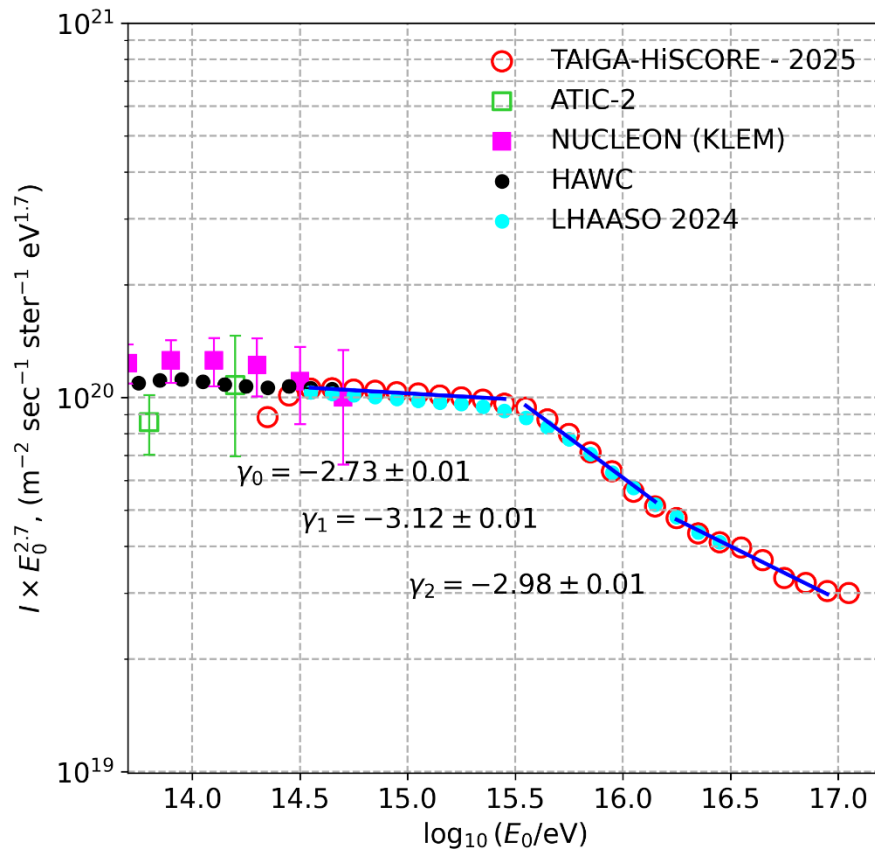

**TAIGA-HiSCORE energy spectrum**

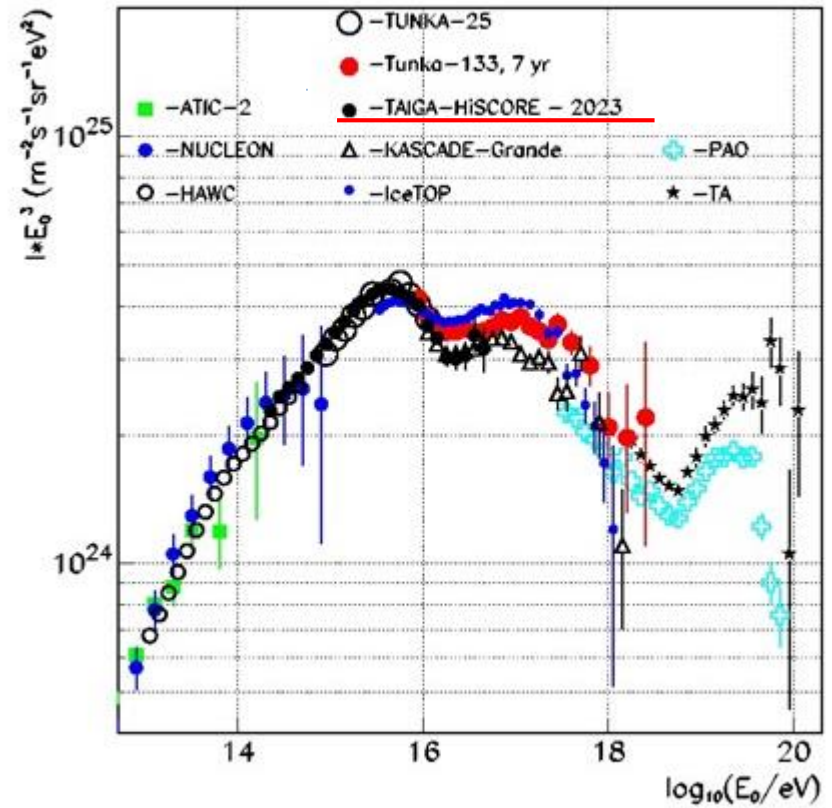

**Comparison of the Tunka-25 & Tunka-133 & TAIGA-HiSCORE energy spectra with other experimental data**

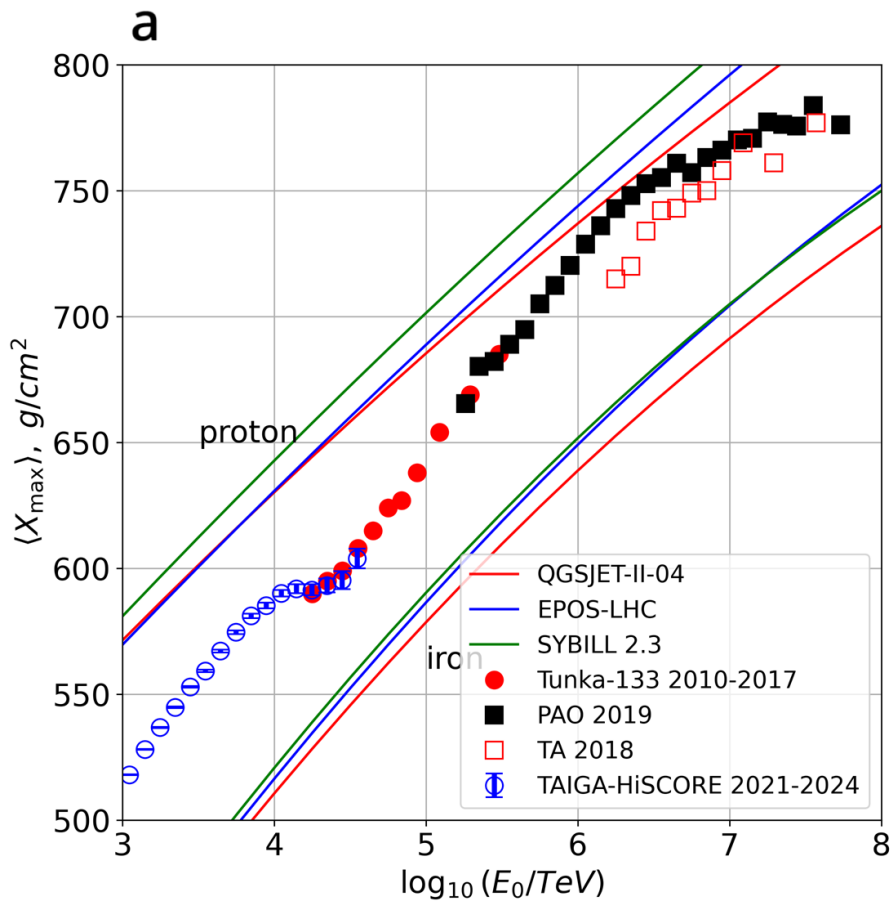

**Mean Depth of EAS maximum**  
 $X_{\max} (\text{g} \cdot \text{cm}^{-2})$

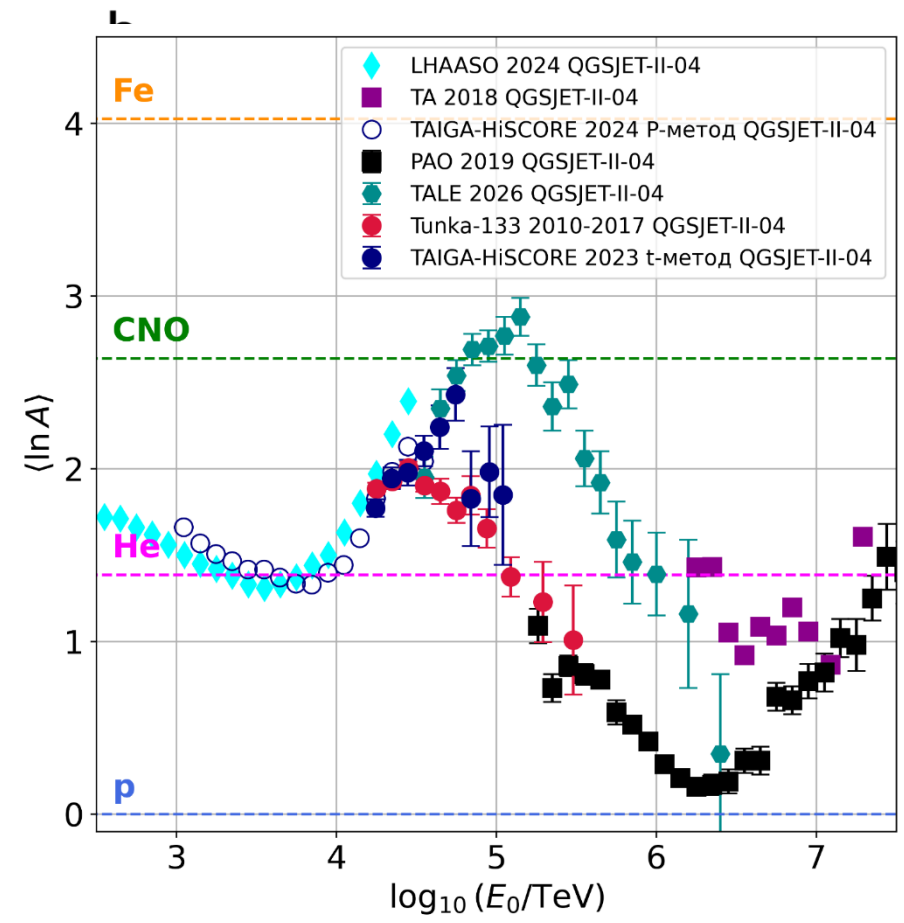

**Mean logarithm of primary mass.**

# Detection of the CR light components (Proton + Helium) using TAIGA-HiSCORE and TAIGA-IACT installations

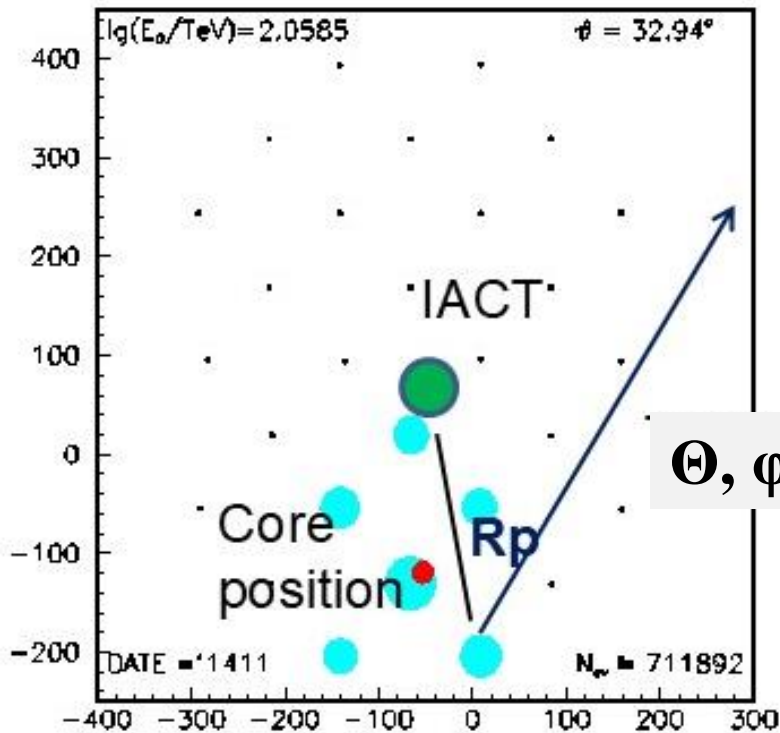

**TAIGA-HiSCORE:**  
energy, direction and core position

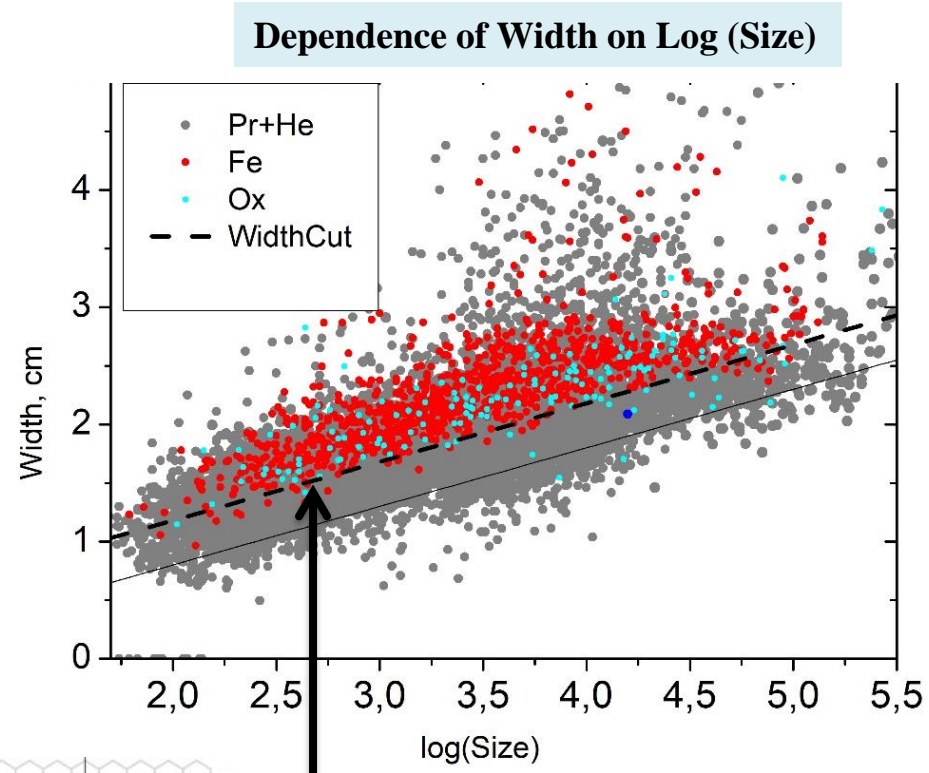

**TAIGA-IACT:** cut on image width

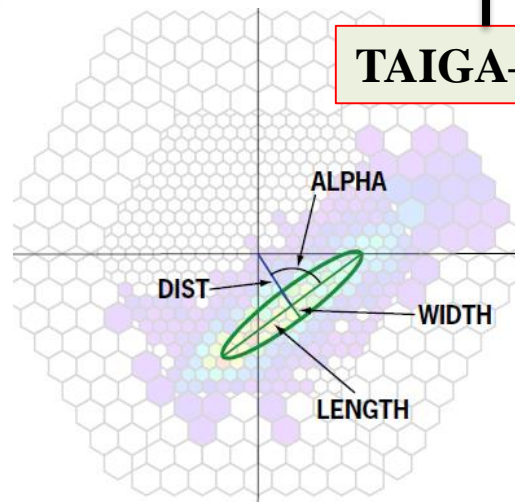

**Size** - total number of PE in EAS image

# Light component of the CR (p, He) in the region of the “knee” based on the results of hybrid measurements.

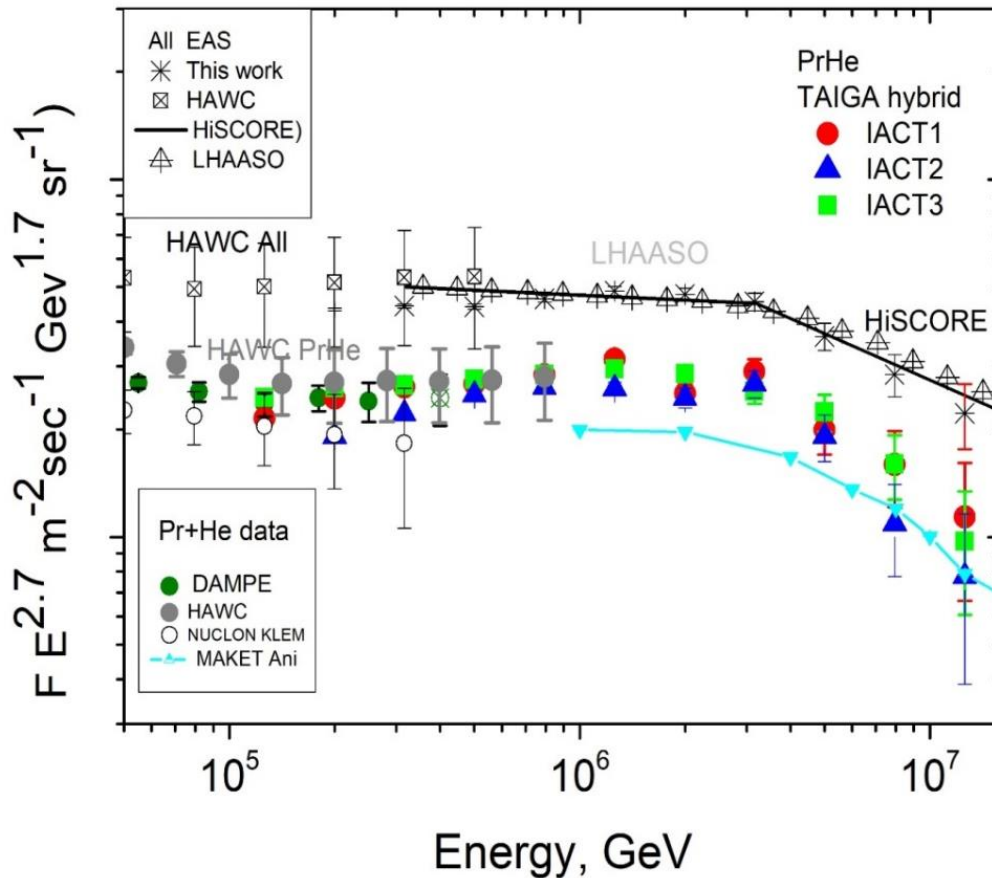

Zenith angle < 25 deg

55 hours

70000 events

1. It is clearly seen a break at an energy of about 3 PeV in the spectra of the light component (P+He).
2. The intensity of P + He in the region of ~200 TeV is in good agreement with the data of the direct DAMPE and NUCLON experiments.
3. It is planned to develop a technique for selecting only protons.

# **High energy gamma astronomy, some first results**

# Four approaches for detecting of gamma rays in the TAIGA experiment by Cherenkov detectors

1. Standalone mode of IACTs operation (  $E > 2-3$  TeV).  
Hadronic background rejection  $\sim 10^{-4}$

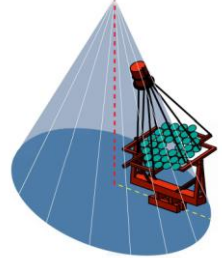

2. Stereoscopic mode for large distances between the IACTs (  $E > 8$  TeV). Hadronic background rejection  $\sim 5 \cdot 10^{-5}$

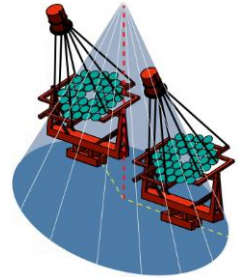

3. Hybrid mode - joint operation of the TAIGA-HiSCORE and some IACTs (  $E > 40$  TeV ). Hadronic background rejection  $\sim 10^{-4}$

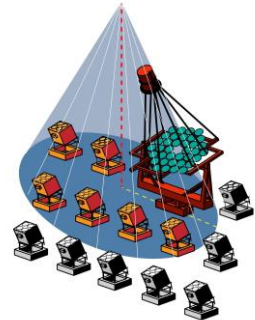

4. TAIGA – HiSCORE,  $E > 300$  TeV (additional hadron suppression is required )

# Observing the Crab Nebula in mono mode

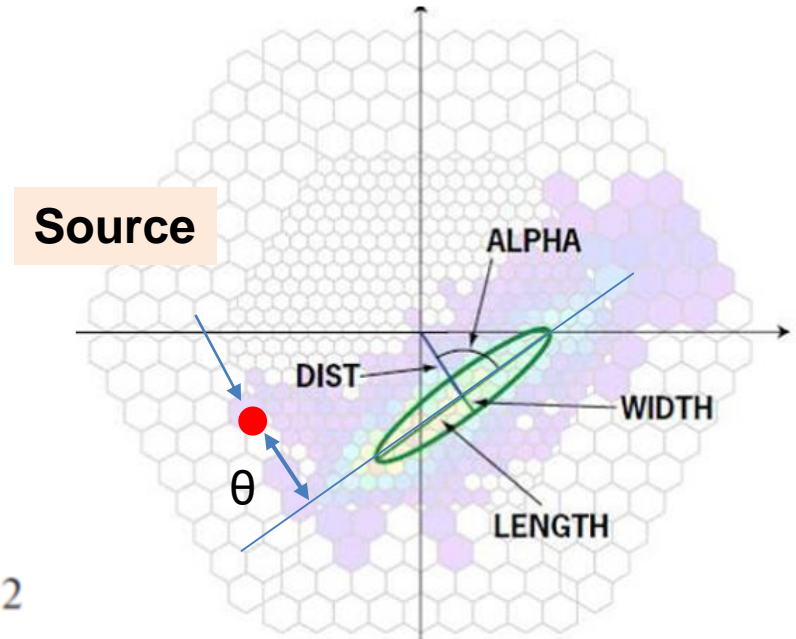
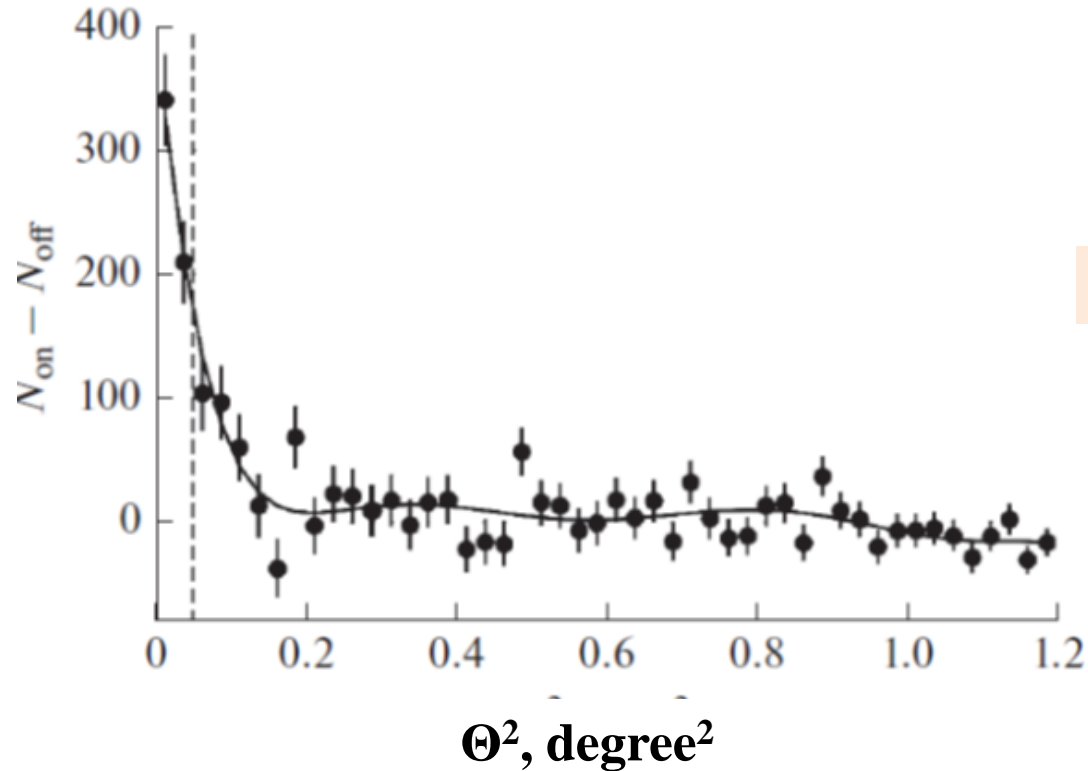

**Background subtracted  $\Theta^2$ -distributions for 150 hours Crab Nebula observation in mono mode**

**Excess is 560 events for 150 hours, significance level 12 $\sigma$**

# The energy spectrum of gamma quanta from the Crab Nebula

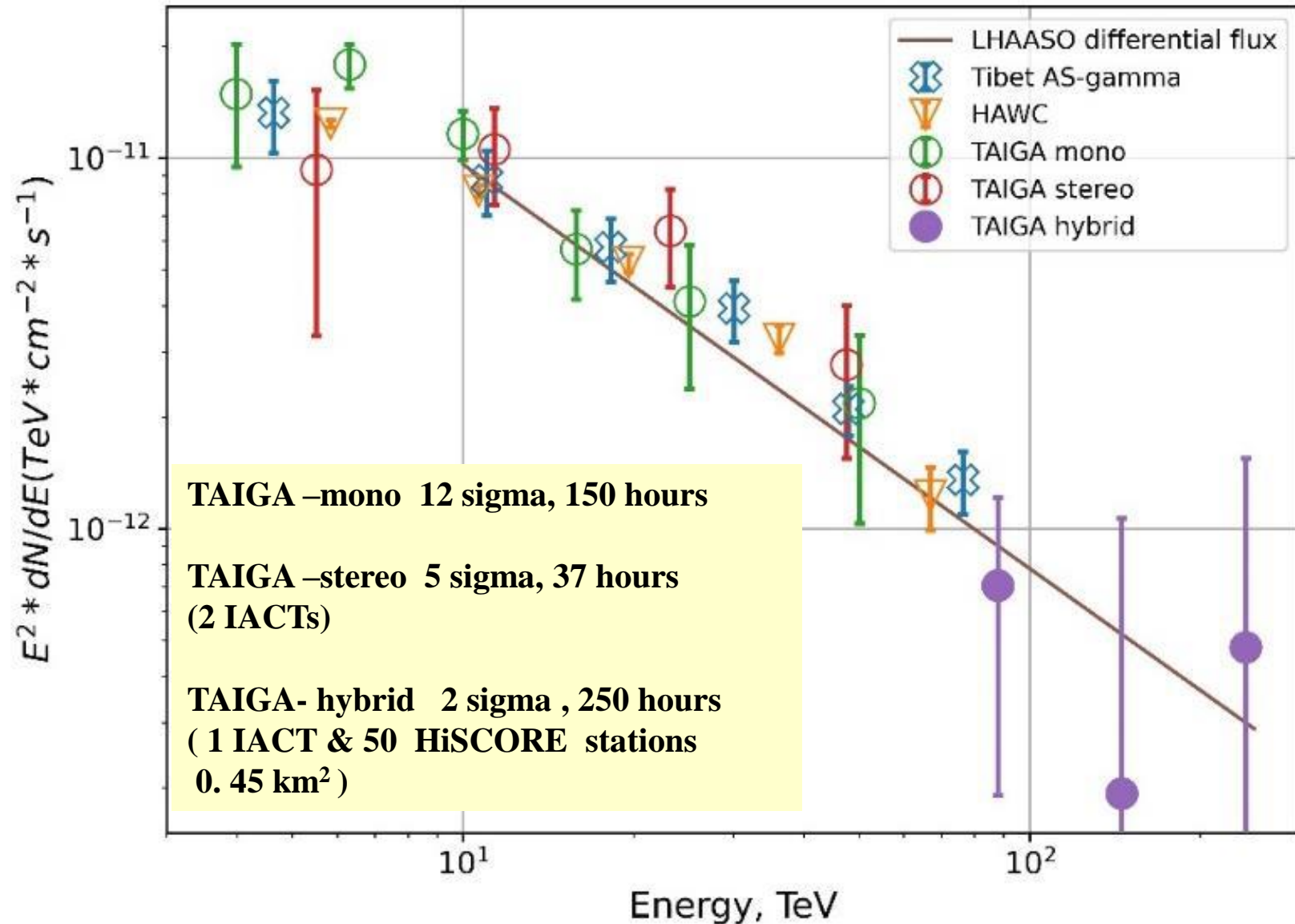

# **TAIGA-100 –**

**Installation with a hybrid  
detector system over an area  
of 100 km<sup>2</sup>**

# TAIGA-100 super station

Wide-angle Cherenkov detector

Scintillation detectors

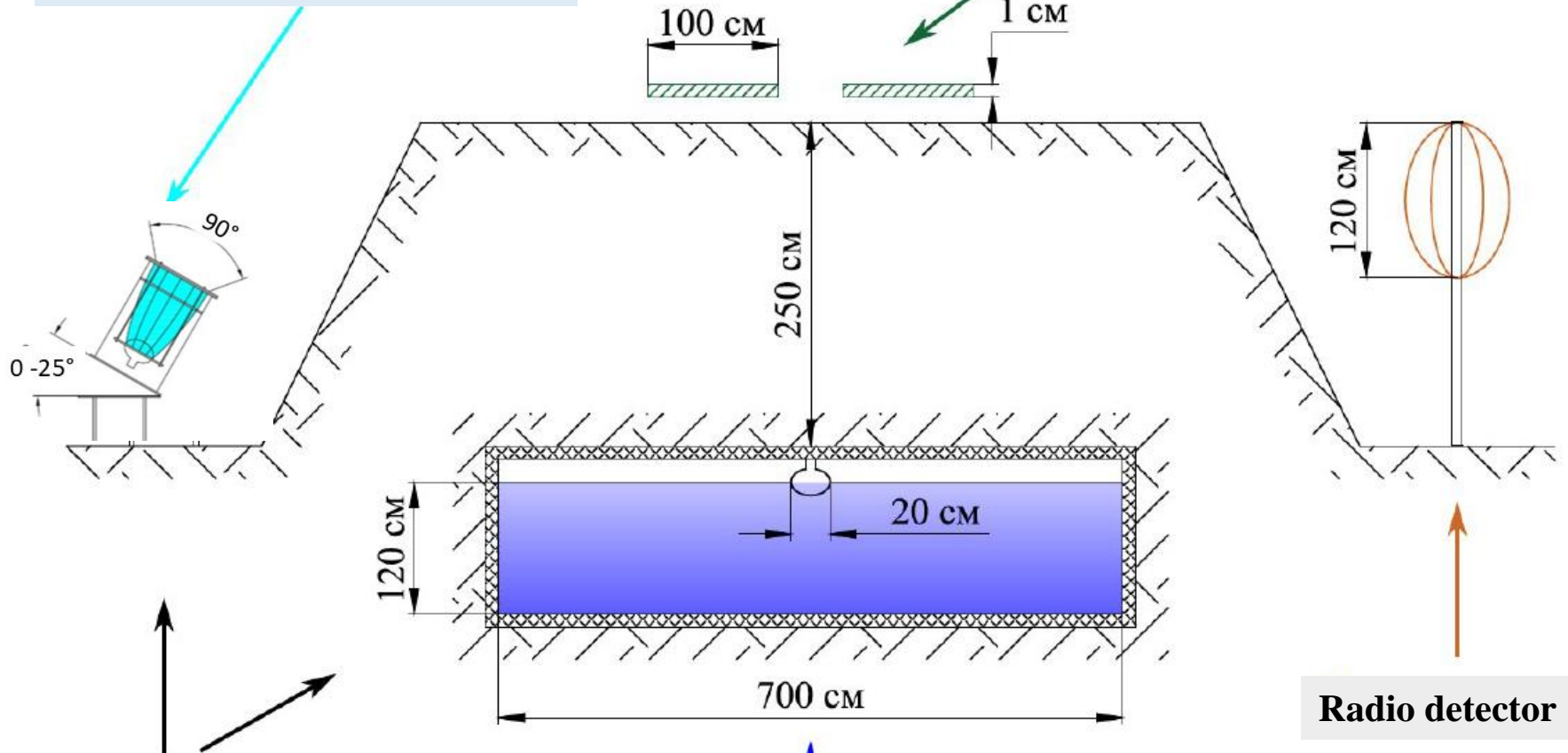

The main detectors

Water Cherenkov detector

Radio detector

# TAIGA-100 – for PeV gamma astronomy

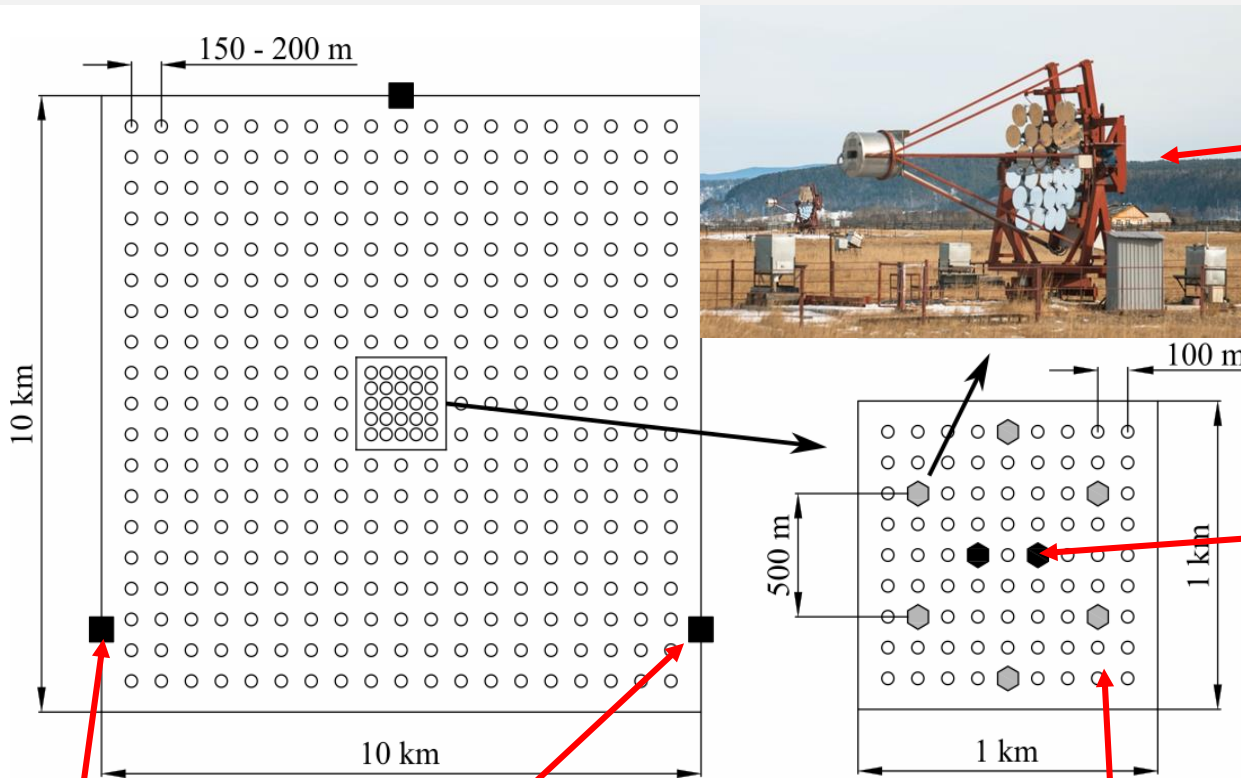

**6 IACTs, D ~ 4 m**  
**2 IACTs, D ~ 10 m**

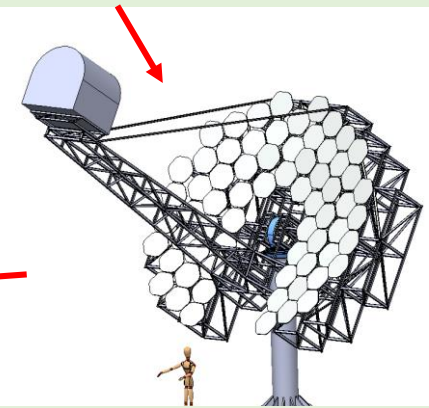

- Davis-Cotton design
- Total reflector area ~ 80 m<sup>2</sup>
- Camera of ~ 2000 pixels (SiPM)
- The threshold for  $\gamma \sim 300$  GeV

## 3 fluorescent Telescopes

- Schmidt design
- Wavelength range 300 - 400 nm
- 7 segmented mirrors, D~60 cm
- Focal length ~1 m
- Telescope viewing angle ~60°

## ~ 3500 Super station (SS):

- wide-angle Cherenkov detector 1 PMT, FoV ~ 2 sr.
- Cherenkov water muon detectors, area 40 m<sup>2</sup>.
- Scintillation detector (1-2m<sup>2</sup>)
- Radio detector

# TAIGA-100 scientific program

## 1. Gamma ray astronomy of high and ultra-high energies.

Gamma-ray astronomy at energies  $\geq 10^{14}$  eV

A search for diffuse gamma rays with energy of  $10^{14}$ - $10^{19}$  eV

A search of GZK photons ( $E = 10^{17}$ - $10^{18}$  eV)

A search for photons from GRB with energy  $> 5 \cdot 10^{12}$  eV

## 2. Cosmic rays in the energy range $10^{14}$ - $10^{19}$ eV.

$E > 10^{17}$  eV -  $10^6$  events per year

$E > 10^{19}$  eV -  $10^2$  events per year

CR mass composition?

The energy of transition from Galactic CR to extragalactic ones.

Are there protons in the range of  $10^{17}$  -  $10^{18}$  eV

## 4. Transient phenomena and gamma bursts.

5. Horizontal showers and showers from neutrinos with energy  $> 10^{17}$  eV

6. Exotics (dark matter, violation of Lorentz invariance, strangelets, etc.)

7. Geophysics - thunderstorms & EAS

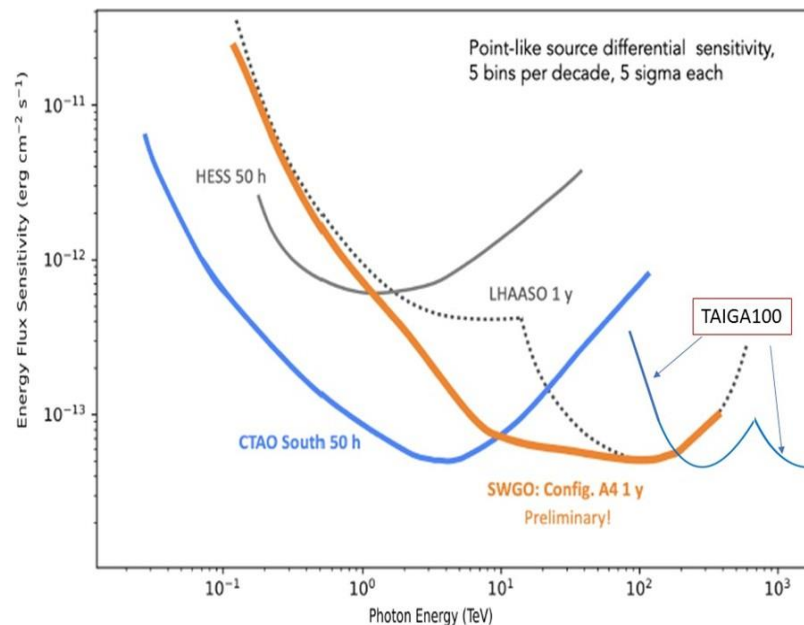

## TAIGA -100

### differential sensitivity

(4 bins per order) 5 sigma or 10 events

# TAIGA-100 & Gamma-ray astronomy

LHAASO sources with energy above 40 TeV

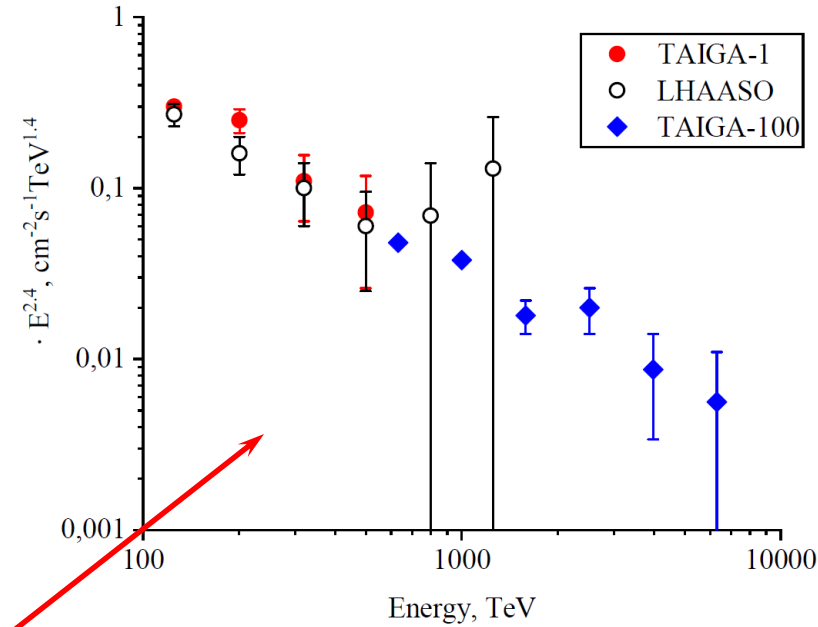
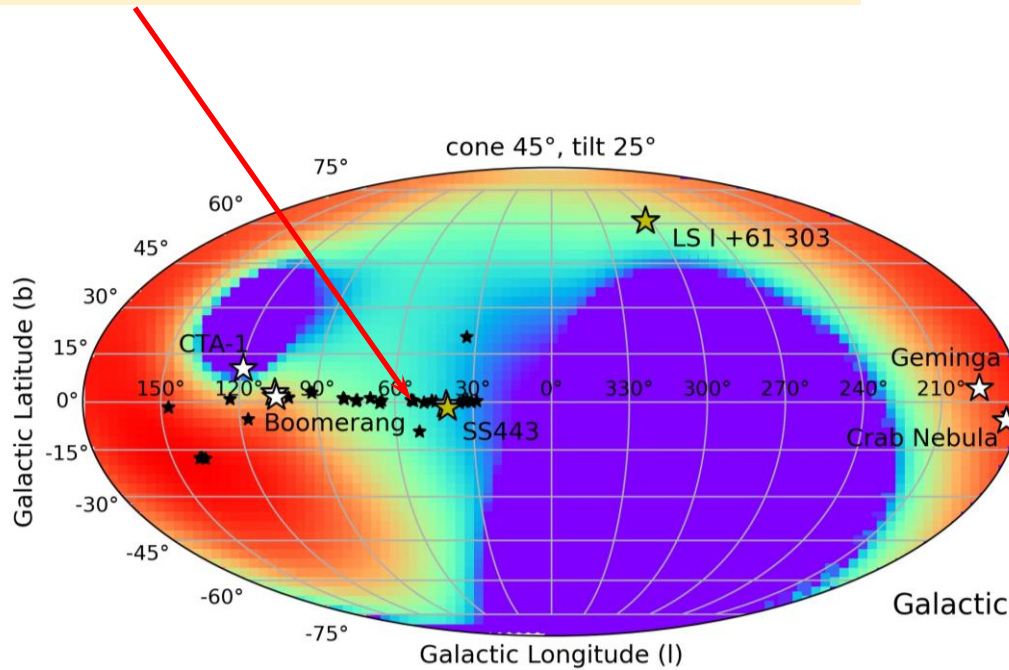

**~ 350 gamma from Crab Nebula with  $E > 500$  TeV for 500 hours of observation ( 3 years)**

**The significance level is 10 sigma**

# Search of GZK photons ( $E = 10^{17} - 10^{18}$ eV)

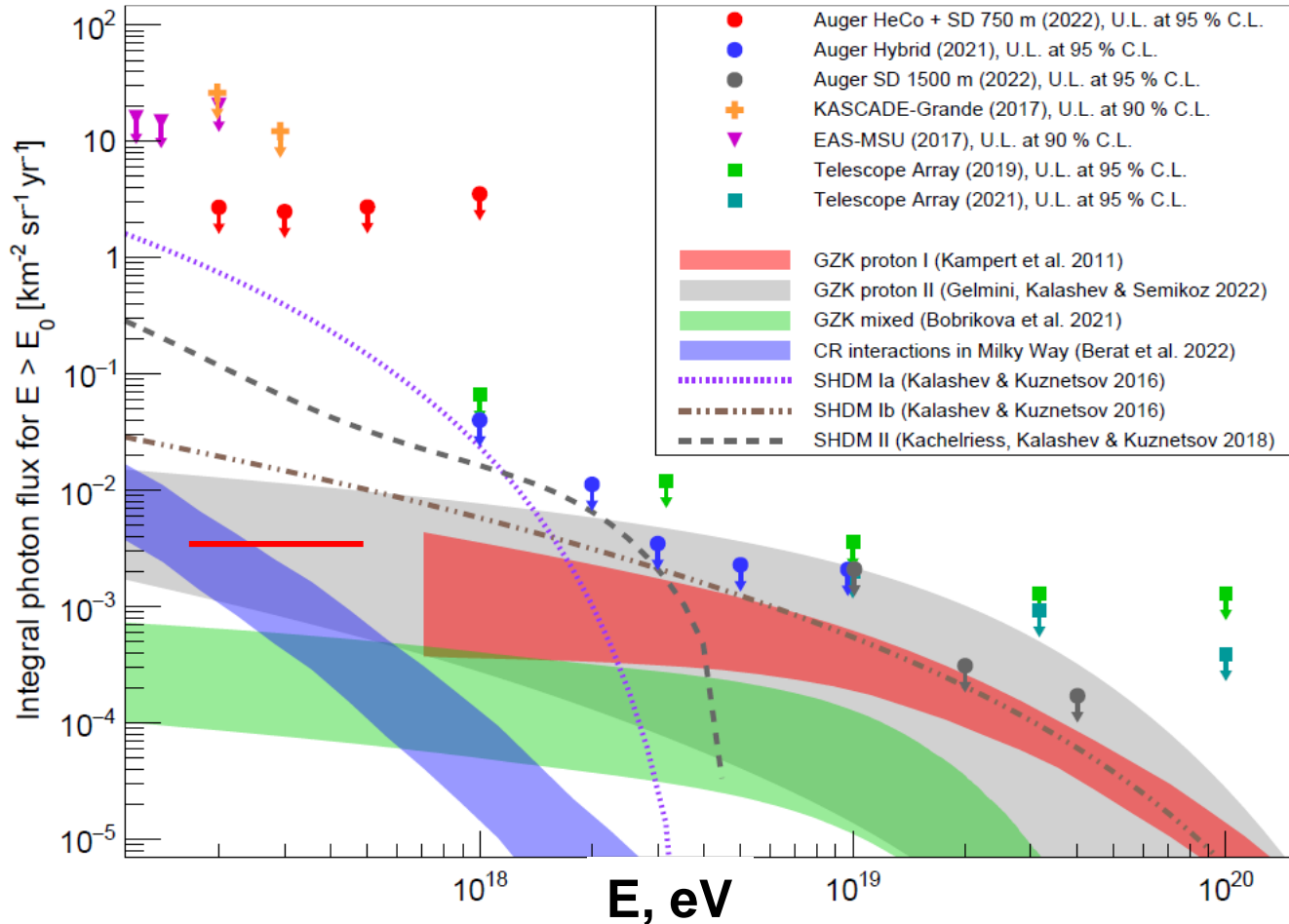

We expect **10 GZK** ( $P + \gamma_{\text{rel}} \rightarrow P + \pi^0 \rightarrow 2 \gamma$ ) **photons** for 10 y  
**or**  
the limit  $\sim 5 \cdot 10^{-3} \text{ km}^{-2} \text{ year}^{-1} \text{ sr}^{-1}$  for 10 y of data taking

# **Near future plan ( 2026 -2029): upgrade of TAIGA-1 & TAIGA-100 engineering array**

- 1. Design for the TAIGA-100 Astrophysical Complex with hybrid detectors system on area about 100 km, including full Monte-Carlo simulating and a site choice.**
- 2. R&D of new detectors for TAIGA-100 facility (wide-angle optical stations, large-area water Cherenkov muon detectors, scintillation detectors, IACTs with SiPM cameras, fluorescence telescopes and radio detectors of EAS).**
- 3. Deployment at the TAIGA-1 site of the fifth IACT with a mirror diameter of 4.3 m and one with a mirror diameter of 10 m.**
- 4. Deployment of the TAIGA-100 engineering array with an area of 0.5 km<sup>2</sup> for testing and common operating with TAIGA-1.**
- 5. A search for a site to host TAIGA-100.**

# A prototype of a water Cherenkov detector, 2025y



In operating since 28/11/ 2025

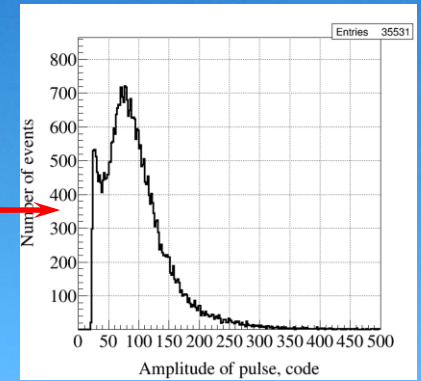
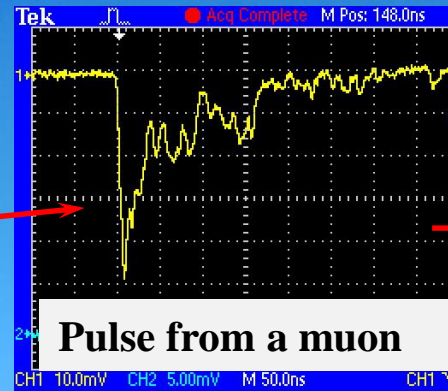

Amplitude distribution



4 scintillation detectors



Water cleaning station

- Hamamtsu R5912 photomultiplier
- Tyvek 1082D reflector
- Filled water volume:  $\sim 6.5 \text{ m}^3$  (R = 1.5 m, H = 90 cm)
- Electrical conductivity of water:  $\sim 5 \text{ } \mu\text{S/cm}$

# The first setup of TAIGA-100, 2026y

Deployment of 3 full-scale water detectors of ~ 40 m<sup>2</sup>  
Upgrade of 49 optical detectors of the Tunka-133 array.  
Prototype of new DAG

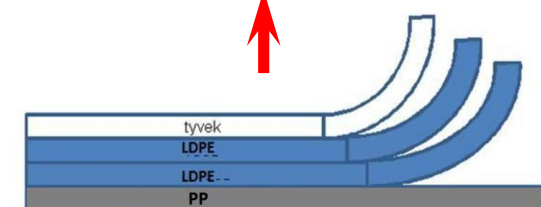
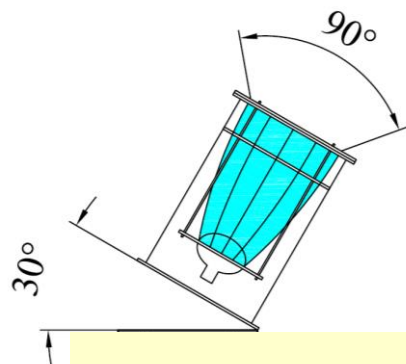
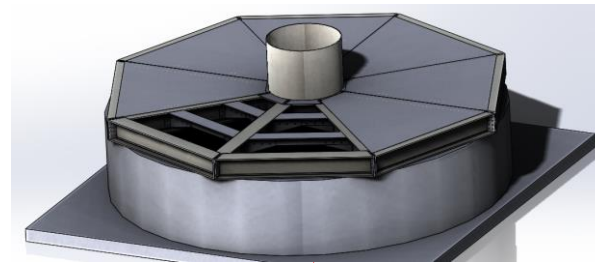
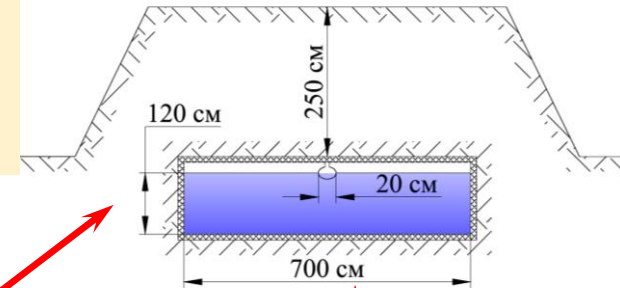
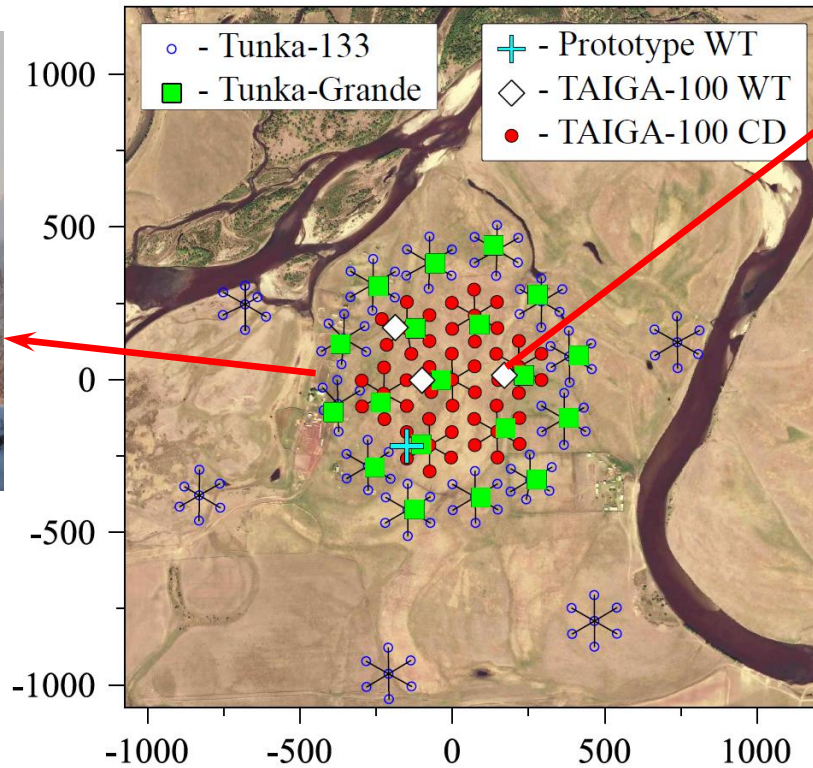

**2030y**

- The full scale TAIGA-100 project
- 0,5 km<sup>2</sup> engineering array at the TAIGA-1 site
- The site for TAIGA-100 selection



# Borgoy steppe – a site for the TAIGA-100

Dzhidinsky District, Republic of Buryatia,  $50.84^{\circ}$  s. w.,  $105.81^{\circ}$  v. d.



Astroclimatic station

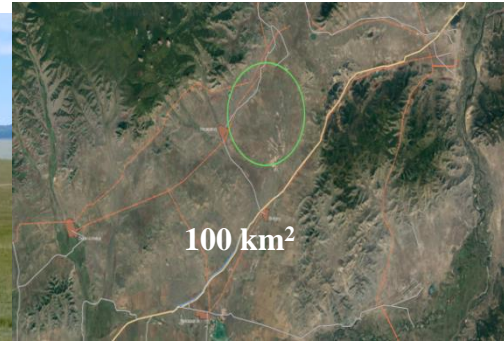

- A lot of cloudless nights ~ 75%
- High air transparency
- Very weak light background
- Area > 100 km<sup>2</sup>
- Altitude of ~ 800 m a.s.l.
- Clean water is available
- Absence of permafrost at the site
- Road and railway
- 3 power lines 35 kV and 110 kV
- Mobile wireless communication
- Optical telecommunication line



# Summary and outlook

**The experience of the first years of operation of the TAIGA-1 confirmed the effectiveness of the hybrid approach to create an installation with an area of tens of square kilometers for UH energy gamma-astronomy.**

**TAIGA-100 opens up unique opportunities for solving problems of ultra-high-energy gamma-ray astronomy and ultra-high-energy cosmic rays and studying many other astrophysical objects and phenomena.**

**R&D work has begun on the TAIGA100 astrophysical complex project. It is planned to test the main TAIGA100 detectors (water Cherenkov muon detector and scintillation detectors, new Cherenkov detector, etc.) and the data collection system at the TAIGA-1 site before choosing a location for the new complex.**

**Thank you  
for attention!**

